



5G-ACIA White Paper

# Integration of OPC UA in 5G Networks

5G Alliance for Connected Industries and Automation

# Table of Contents

1	Executive Summary	3
2	Introduction	3
3	Overview of OPC UA FX: Information Model and Engineering Workflow	4
3.1	Automation Components	4
3.2	From Functional Entity to Communication	5
3.3	Connection Managers	6
3.4	OPC UA FX Engineering Workflow	9
4	Use Cases and Deployment Scenarios for OPC UA FX and 5G Integration	13
4.1	Use Cases	13
4.2	OPC UA Application Deployment Scenarios	15
5	5G and OPC UA Integration Architectures	16
5.1	Integration Principles	16
5.2	Overall Architecture and Key Interfaces	16
5.2.1	Transport Mapping	16
5.2.2	Joint QoS and Connectivity Management	17
6	Joint QoS Management	19
6.1	OPC UA QoS Configuration	19
6.2	5G QoS Management	21
6.3	Joint QoS Management Between OPC UA and 5G	23
6.3.1	5G QoS Derived from <i>PriorityLabel</i>	23
6.3.2	5G QoS Derived from Extended QoSDataType	25
6.4	Interface for Joint QoS Management	27
7	Connectivity Management	28
7.1	OPC UA FX Controller Connectivity Management Service Integration Analysis	28
7.2	Exposure of 5G Connectivity Management Services	31
7.3	Interface for Connectivity Management Services	32
8	Conclusions	33
9	Abbreviations and Acronyms	33
10	References	34
11	5G-ACIA Members	36

# 1 Executive Summary

## About 5G-ACIA

The **5G Alliance for Connected Industries and Automation** (5G-ACIA) was established to serve as the main global forum for addressing, discussing, and evaluating relevant technical, regulatory, and business aspects of 5G for the industrial domain. It embraces the entire ecosystem and all relevant stakeholders, which include but aren't limited to the operational technology industry (industrial automation companies, engineering companies, production system manufacturers, end users, etc.), the information and communication tech-

nology industry (chip manufacturers, network infrastructure vendors, mobile network operators, etc.), universities, government agencies, research facilities, and industry associations. 5G-ACIA's overarching goal is to promote the best possible use of industrial 5G while maximizing the usefulness of 5G technology and 5G networks in the industrial domain. This includes ensuring that ongoing 5G standardization and regulatory activities adequately consider relevant interests and requirements and that new developments in 5G are effectively communicated to and understood by manufacturers.

## 2 Introduction

The OPC Unified Architecture (OPC UA) is a widely accepted cross-platform, open-source industry standard that provides a framework for industrial interoperability by enabling secure, reliable communication among devices, controllers, machines, and systems of different manufacturers via the same interface. It is now already being adopted by mainstream equipment manufacturers to support communication between controllers and devices and from devices and controllers to the cloud. As 5G and its networking capabilities evolve and grow, OPC UA has potential for more comprehensive use in the industrial domain while also taking advantage of the greater flexibility offered by mobile communication technologies.

OPC UA Field Exchange (OPC UA FX), based on the existing OPC UA framework, is used for field-level communication. It enables cross-vendor interoperability in an open, unified, standardized Industrial Internet of Things (IIoT) communication solution that broadens OPC UA to include field-level communication and addresses the full range of use cases in process and factory automation. OPC UA FX covers automation components (serving as a basic model for controllers, devices and so on), offline configuration, communication mechanism (including *Connection* management, bootstrapping, device deployment, etc.).

Against the background of the rapid evolution and networking capabilities of 5G, this paper evaluates the possibility of integrating OPC UA in it, focusing mainly on ways to support use cases involving OPC UA FX and field-level communications (FLC), which have more demanding requirements in terms of network performance, functionality, and operation. It looks at the overall architecture, relevant interfaces, information model, procedures, and other crucial aspects of integrating OPC UA and 5G. In addition, technical schemes (including transport mapping, QoS mapping, and management plane mapping) are analyzed in detail to provide a better understanding of how integration of OPC UA and 5G could work in actual practice.

# 3 Overview of OPC UA FX: Information Model and Engineering Workflow

## 3.1 Automation Components

OPC UA systems for field-level use expose their information while applying a prescribed OPC UA FX information model. Information models are based either on *Automation Components* (ACs) or on entities that perform one or more functions of an automation device, such as a controller, drive, instrument, or I/O device. Each AC is modeled as one or more *Assets* and/or *FunctionalEntities* (FEs). Each AC also contains information describing the network interfaces used and the network and communications services it supports. An AC's scale is vendor-dependent: it can be as small as an individual stand-alone I/O device or as large as a complex room-sized machine.

There are two major types of ACs, *Asset* models and functional models:

- An *Asset* model typically describes a physical entity but can also be a nonphysical entity such as firmware or a license.
- A functional model involves logical functionality. It comprises one or more FEs with features such as input/output variables, device parameters, or communication links. An FE is abstracted from the hardware to facilitate porting of applications to new equipment.

Figure 1: Connection types

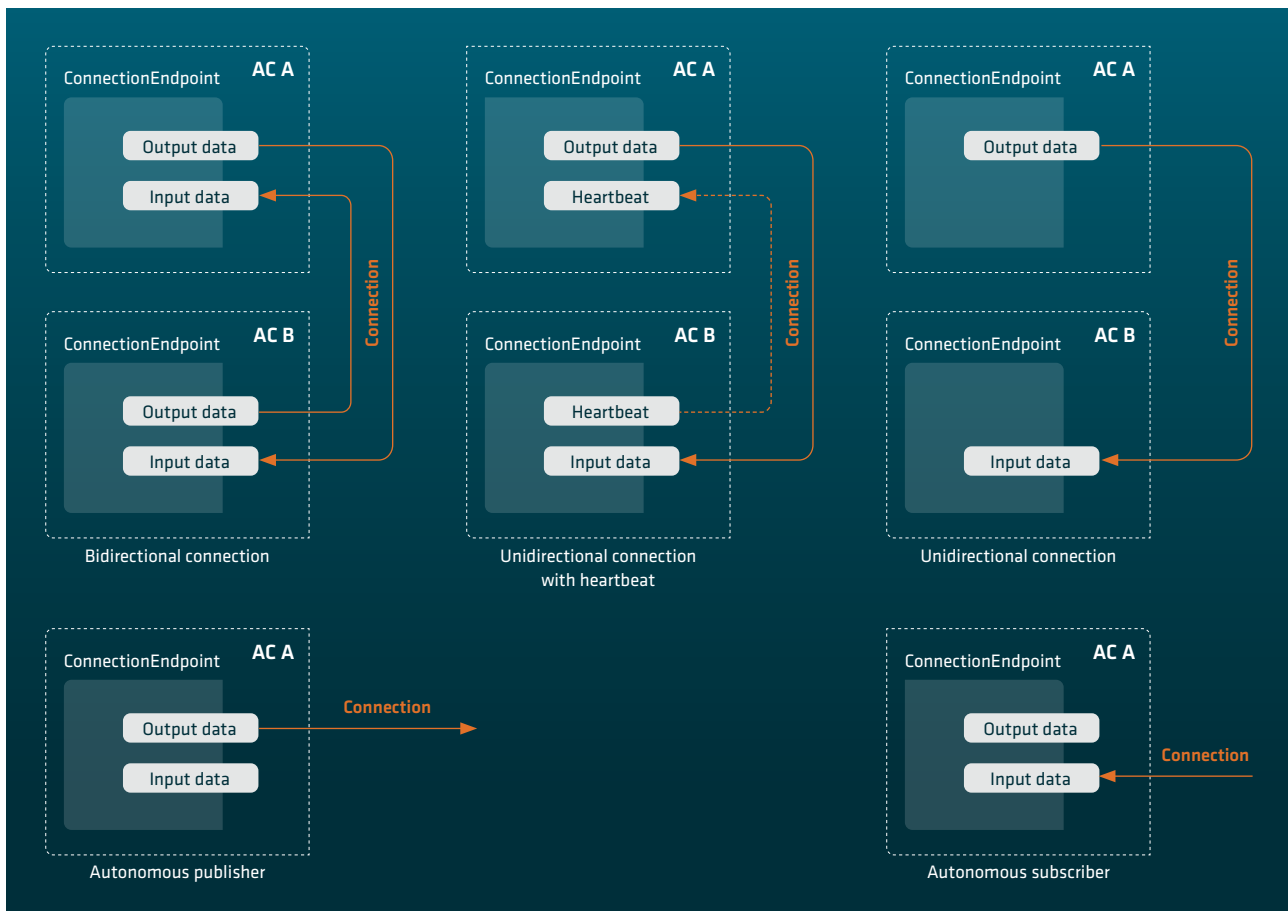

Source: 5G-ACIA / ZVEI e. V.

FEs are used to reference *Assets* with which they are associated or on which they are executed. They also make it possible for applications to confirm that certain hardware requirements are met. For example, a two-axis drive can be a single *Asset* comprising two FEs.

### 3.2 From Functional Entity to Communication

An FE is a building block representing an AC's functionality. Examples include an application execution engine, a motion axis controller, a sensor, a relay, an I/O controller, and a variable-frequency drive controller.

**Figure 2:** A single *Connection* with unicast network messages

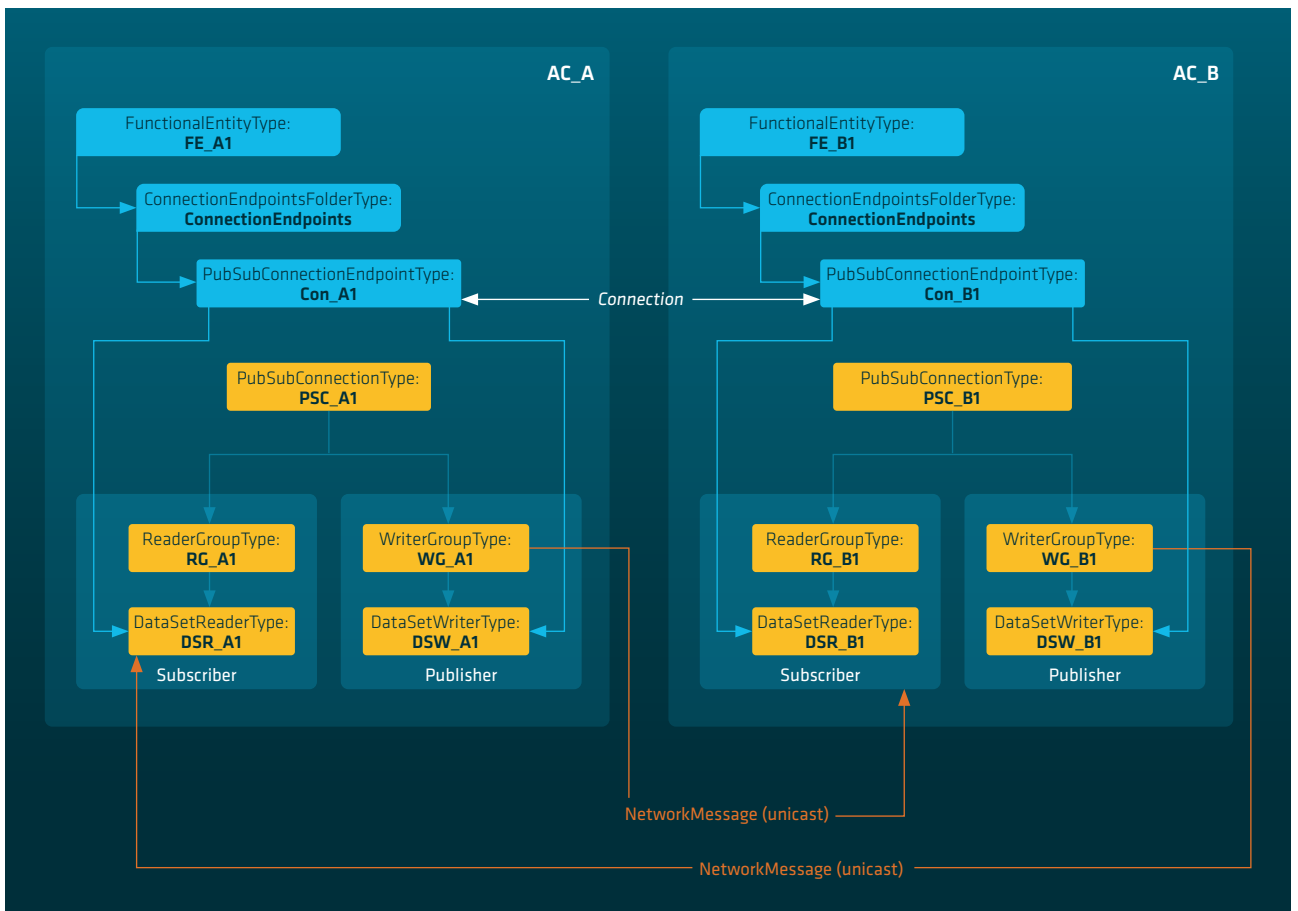

Source: 5G-ACIA / ZVEI e. V.

*Connections* are logical communication relationships that FEs use to exchange a defined set of process data and data quality information. A *Connection* is characterized by two *ConnectionEndpoints*, one on each FE that forms part of the *Connection*. *Connections* are configured using *ConnectionConfigurationSets*. Five different types of *Connections* are supported, as shown in figure 1:

- Bidirectional *Connections* send data between two FEs in both directions.
- Unidirectional *Connections* involve sending data from one FE to another in one direction only.
- Unidirectional *Connections* with a heartbeat involve sending data in a single direction between two FEs while a heartbeat message (for monitoring of logical *Connections*) is transmitted in the opposite direction.
- An autonomous *Publisher* describes an FE that sends data without the corresponding subscribing *ConnectionEndpoint(s)* being known to the logical *Connection*.
- An autonomous *subscriber* describes an FE that receives data without the subscribing *ConnectionEndpoint(s)* being known to the logical *Connection*.

*Connections* between FEs are basically intended to exchange data using OPC UA communication models, which come in two kinds: PubSub (a “publish-subscribe” messaging pattern in which publishers send messages belonging to different classes of subscribers) and *ClientServer*. At the time of this paper’s publication, only the PubSub communication model is supported for exchanging data via *Connections*; see reference [1], section 5.5.6.

Figure 2 shows a single logical *Connection* between two FEs: FE\_A1 and FE\_B1 residing in AC\_A and AC\_B, respectively. Each FE contains a publisher, a subscriber, and a single *PubSubConnectionEndpoint* (Con\_A1 for FE\_A1 and Con\_B1 for FE\_B1). In this example, either both FEs can publish data (=bidirectional *Connection*) or only one while the other publishes a heartbeat (=unidirectional *Connection* with a heartbeat).

Note that in figure 2, both PubSub instances are configured to exchange data between ACs using unicast communication. Figure 3 shows another example involving multicast communication. Here, an AC (AC\_A) communicates with multiple ACs (AC\_B and AC\_C). FE\_A2, which is part of AC\_A, needs to communicate with both FE\_B2 and FE\_C1, which reside in different ACs. In this case, instead of using unicast communication between the members of each individual AC pair, AC\_A can aggregate the published data in a single *NetworkMessage* and use multicast communication to send it to the associated ACs. In the opposite direction, AC\_B and AC\_C send unicast *NetworkMessages* back to AC\_A.

### 3.3 Connection Managers

A *ConnectionManager* (CM) is an entity that interacts with *AutomationComponents* to establish *Connections* between *FunctionalEntities*. It uses data such as addresses, an update rate, and QoS settings to configure the communication. According to the latest C2C release of OPC UA FX, connection information is stored in the CM, which receives it from an offline engineering tool in the form of a *ConnectionConfigurationSet*.

The CM is modeled as a distinct entity that can reside in a *Controller* or any other UAFX server. The *ConnectionConfigurationSetType* (the *Object* type defined in reference [1] for one or more *ConnectionConfigurations*) has the following parameters:

Figure 3: Multiple Connections with multicast network messages

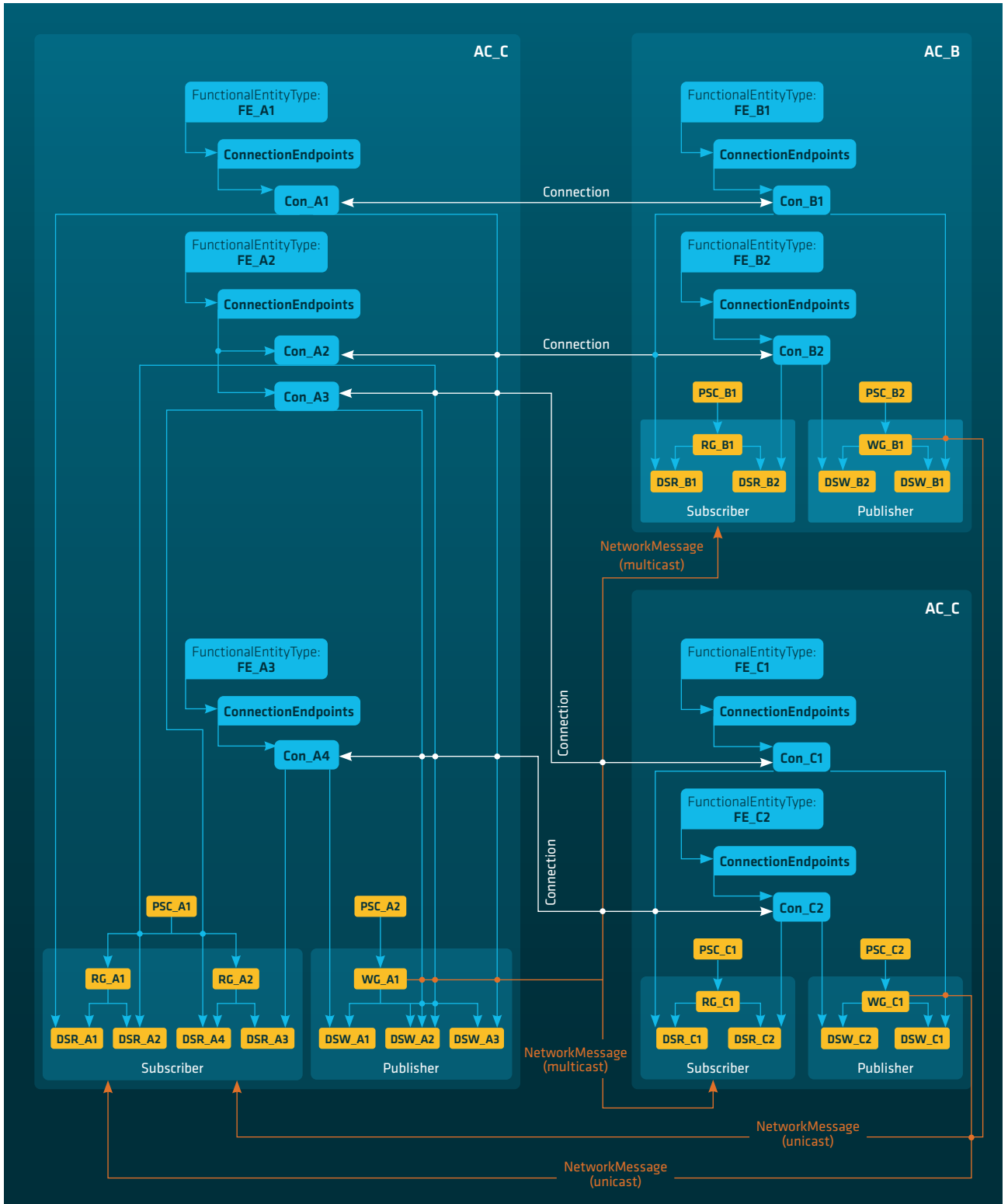

Source: 5G-ACIA / ZVEI e. V.

**Figure 4:** OPC UA FX engineering workflow

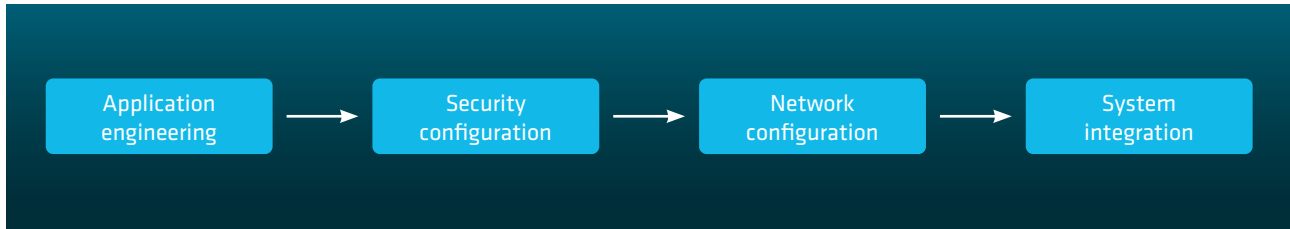

Source: 5G-ACIA / ZVEI e. V.

**Figure 5:** OPC UA FX application engineering

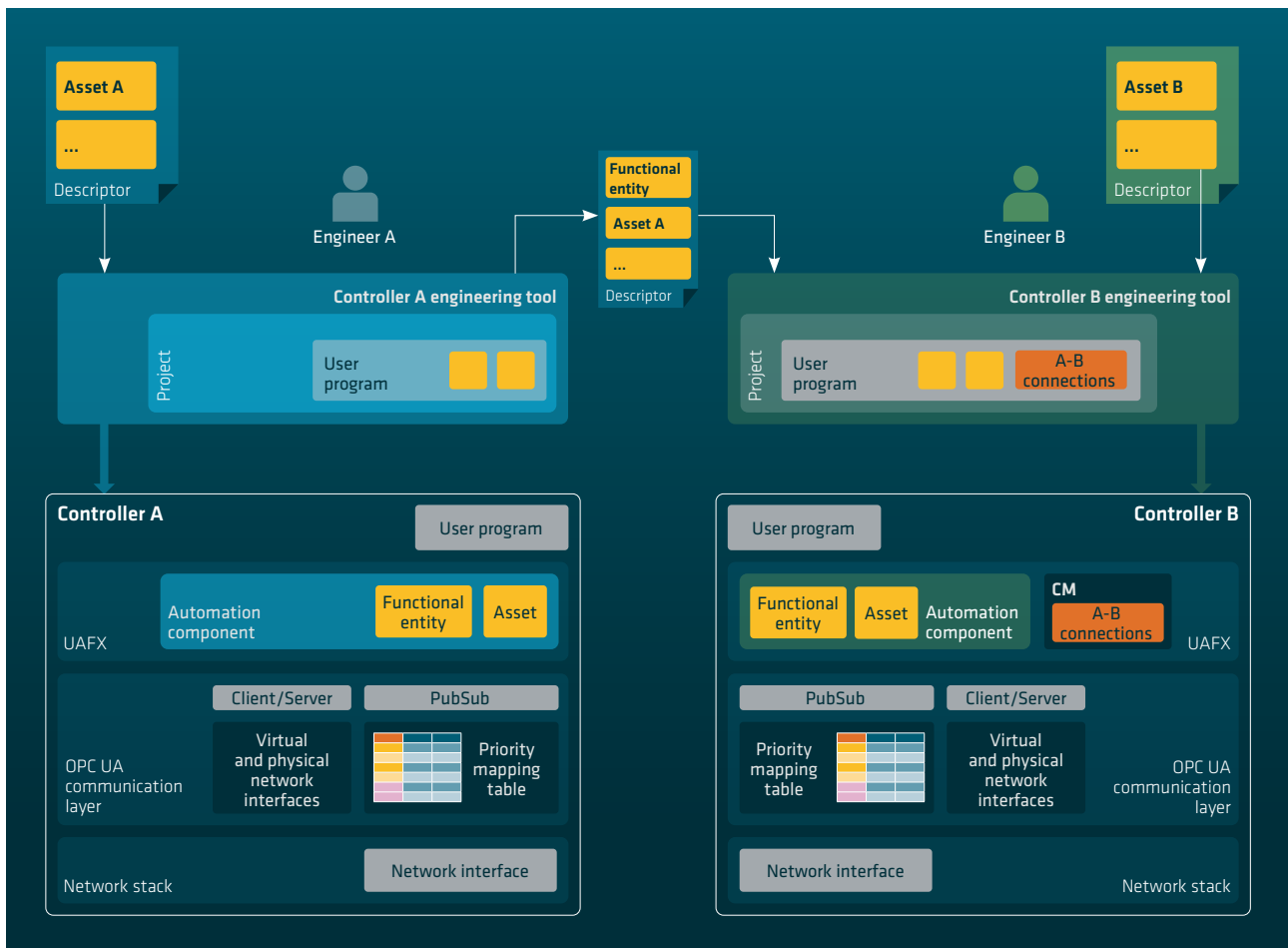

Source: 5G-ACIA / ZVEI e. V.



- Description of the endpoints to be connected
  - A local address (the address of the OPC UA server located on the AC) and the browse path for connecting to the FE
  - A remote address
- Choice of unicast or multicast
- The QoS option and its parameters
- For process data:
  - *PublishingInterval* (for the data publisher)
  - *MessageReceiveTimeout* (for the data subscriber)
- For the heartbeat:
  - *PublishingInterval* (for the heartbeat publisher)
  - *MessageReceiveTimeout* (for the heartbeat subscriber)
- *Connection* timeout (for cleanup)
- Compatibility verification parameters

### 3.4 OPC UA FX Engineering Workflow

OPC UA FX defines a mechanism for standardizing exchanges of information for establishing *Connections* between ACs in an offline engineering environment (see figure 4). From initial AC development to on-site commissioning, engineers use *Descriptors* to exchange offline data: available inputs, outputs, configuration data, and communication capabilities of *Assets* and *FunctionalEntities* (FEs) used in applications. This lets them use their engineering tools to add product and system configuration data in each phase of the workflow until the configuration is ready for deployment in the field.

#### Application Engineering

Figure 5 shows an example engineering workflow in which engineers A and B work together to create a control application consisting of controllers A and B, which are separate in time and space and don't necessarily include physical devices. Engineer A uses an engineering tool specific to *Controller A* to create both the user program for it and the corresponding UAFX information model, which is an AC representing the entity created by engineer A. The FEs in the AC define the user program's logical functionality using input and output variables to expose the data to be exchanged via *Connections* with other FEs in another *Controller*; in this scenario, it could be *Controller B*.

When the configuration for *Controller A* is finished, engineer A uses the same engineering tool to transfer the resulting user program and export a *Descriptor*, which is also shared with engineer B, containing the AC, FEs, and other relevant information. The AC's *PublisherCapabilities* and *SubscriberCapabilities* variables describe the communication capabilities that it supports, such as publishing intervals and QoS capabilities.

Similarly, engineer B creates a user program and information model for *Controller B* using another *Controller*-specific engineering tool. Engineer B also imports the descriptor using *Controller B*'s engineering tool and adds the information that is needed to configure the logical *Connection* between the FEs in the two *Controllers*. After importing the descriptor from *Controller A*, *Controller B*'s engineering tool now contains the information model for both *Controllers*, including the configurations of both *Controllers*' ACs. Engineer B then uses this information to configure the QoS and addresses for each *Connection* between the *Controllers* by setting the sender and receiver address and the *QosCategory* and *PriorityLabel* in the CM. Note that the network-specific QoS mechanisms (such as VLAN PCP, IP DSCP, and 5G QCI) aren't directly configured.

### Security Configuration

The security administrator uses a security provisioning entity to configure the *Controllers* for OPC UA security and rolls out the security policy required for each *Controller* at the site as shown in figure 6. The security policy covers certificates, roles, and user management, among other things. In the case of PubSub, this includes configuring the *SecurityKeyServer*. The security administrator may use a *GlobalDiscoveryServer* for security configuration.

Figure 6: Security configuration

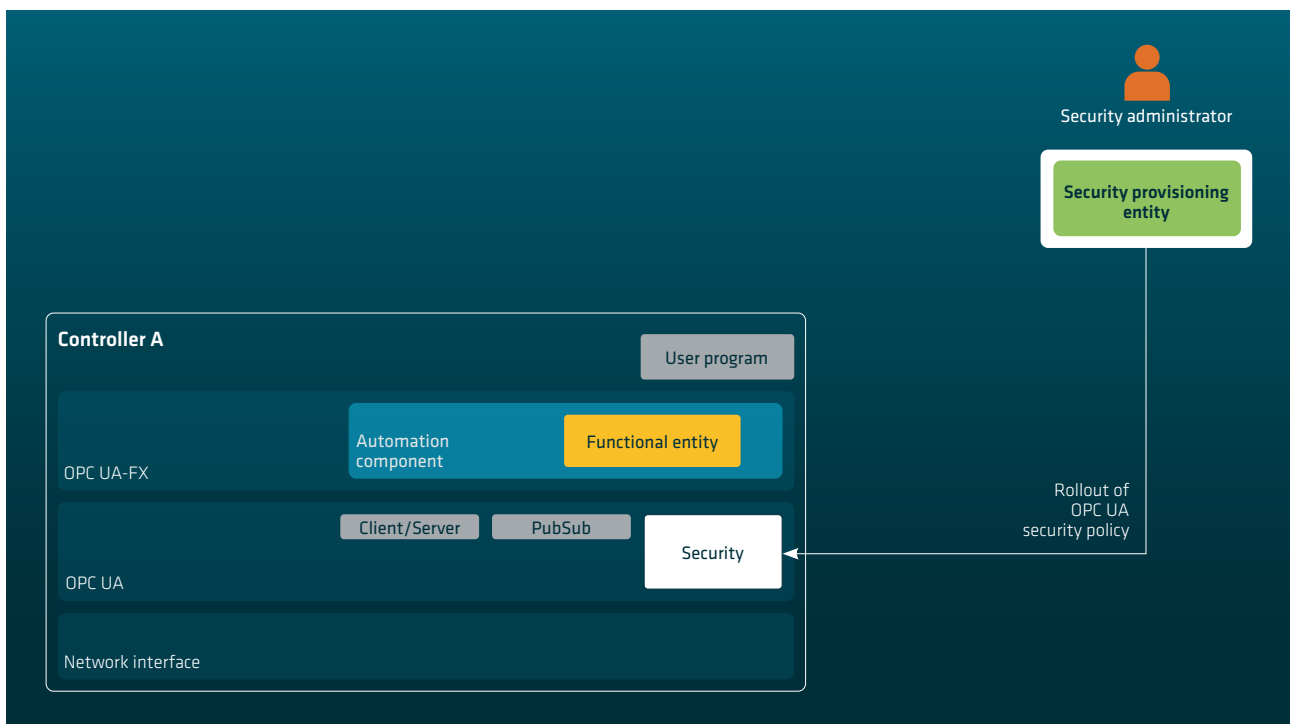

Source: 5G-ACIA / ZVEI e. V.

### Network Configuration

The network engineer commissions the controllers with a hostname, DNS information, and an IP address or address acquisition mechanism such as DHCP. Firmware or software updates can be applied if required. Using a Network Provisioning Entity, the network engineer then rolls out the network configuration as required for the site using vendor-inde-

pendent mechanisms and tools. Figure 7 illustrates this. The network configuration includes VLAN use, time synchronization, and QoS, among other things.

For TSN, the OPC UA FX commonly uses the mechanisms defined in the TSN Profile for Industrial Automation (IEC/IEEE 60802).

Figure 7: Network configuration

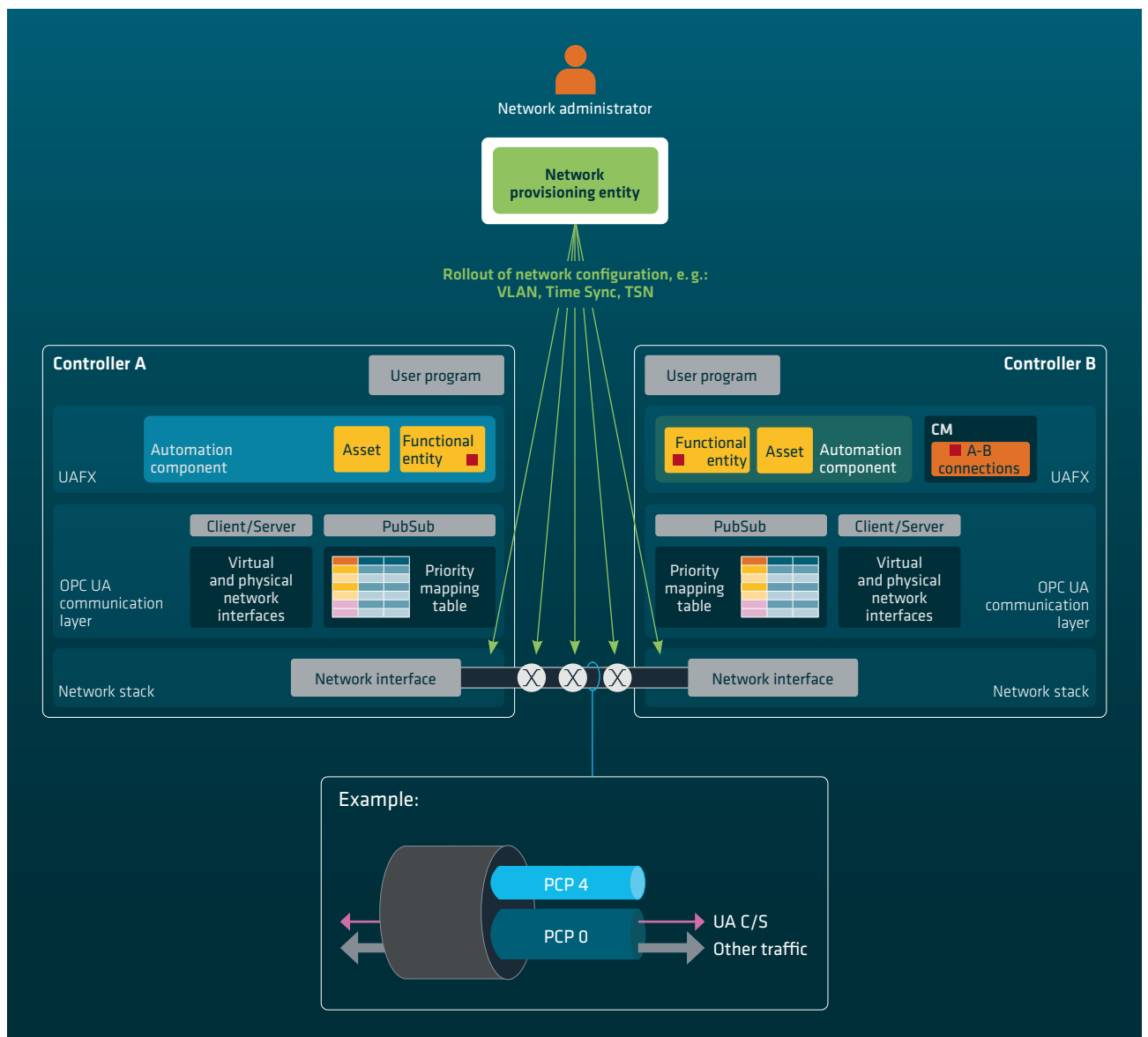

Source: 5G-ACIA / ZVEI e. V.

### System Integration

The system commissioner can adjust the *Connection* configuration – such as addresses of *Connection* partners, publishing intervals, or QoS mapping tables – using a generic OPC UA Client or a tool based on standard OPC UA Client/Server services, as shown in figure 8.

Figure 8: Connection commissioning

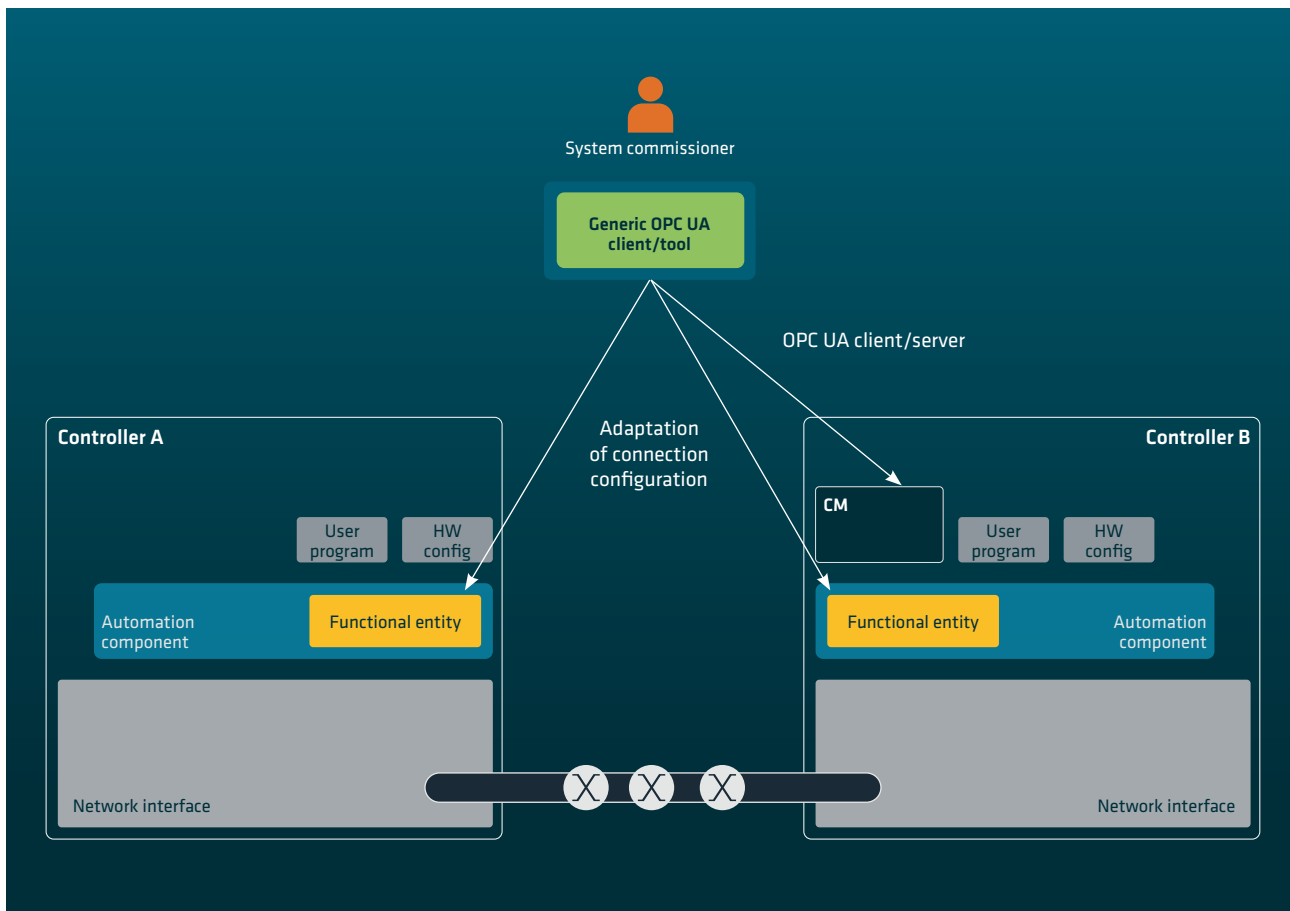

Source: 5G-ACIA / ZVEI e. V.

## 4 Use Cases and Deployment Scenarios for OPC UA FX and 5G Integration

### 4.1 Use Cases

The targeted use case for OPC UA FX and 5G integration is controller-to-controller (C2C) communication, in other words communication between industrial controllers (see reference [2]). There are two typical scenarios: large-scale equipment such as newspaper printing presses and applications in which multiple individual machines collaborate to perform a shared

task (for example, along an assembly line) and need to communicate with one another to accomplish this.

Industrial controllers typically need to be synchronized with one another for these applications. They also have very strict requirements in terms of end-to-end latency, message integrity, and the availability and reliability of communication services. See reference [3].

**Figure 9:** C2C use case for integrating OPC UA FX and 5G

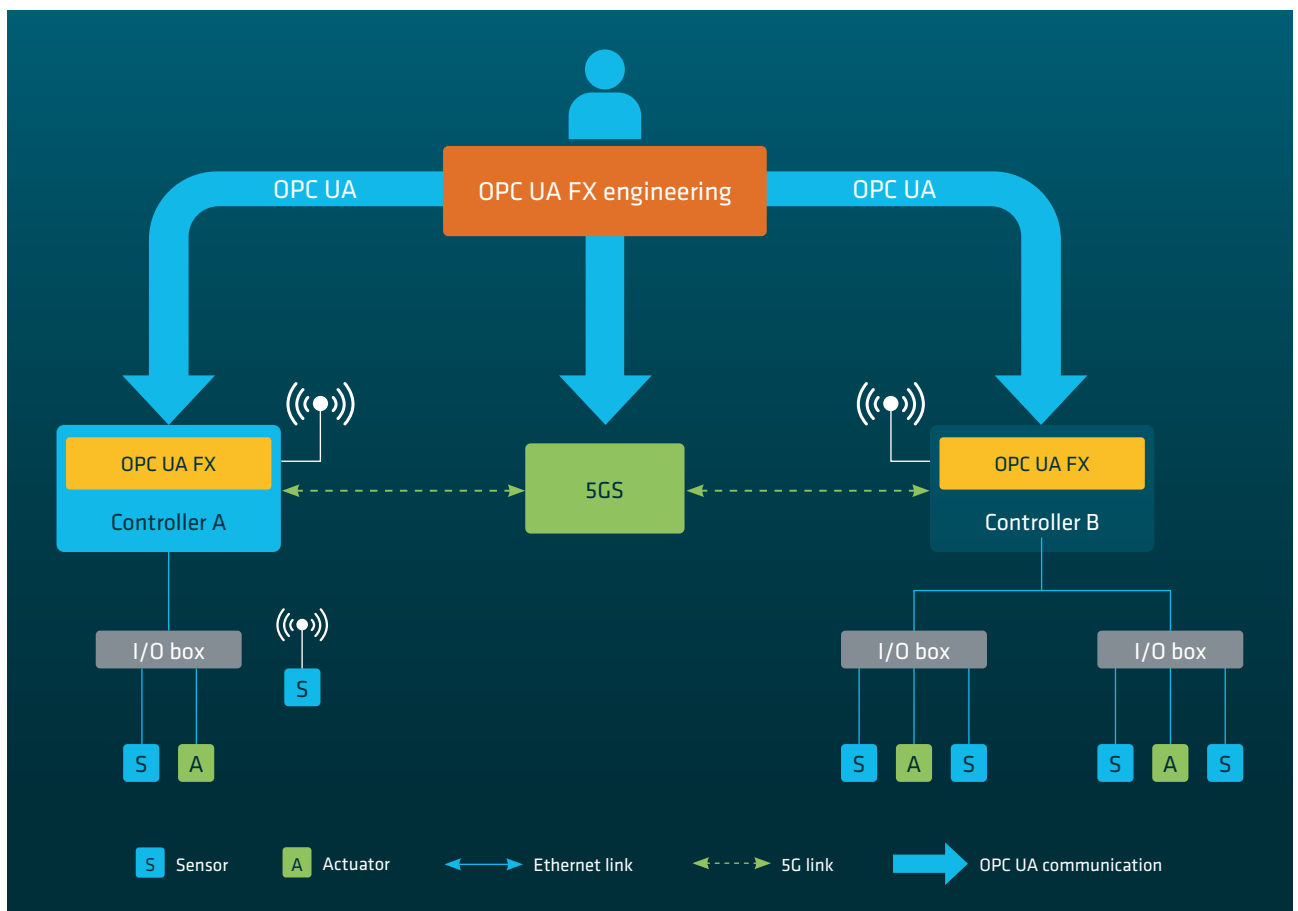

Source: 5G-ACIA / ZVEI e. V.

Figure 9 shows an example C2C use case in which:

- *Controllers A and B* are 5G industrial devices that can include 5G modules and/or connect to 5G gateways to support 5G transmission.
- OPC UA FX represents an industrial application that supports OPC UA specifications to enable devices to exchange data, regardless of whether they are from the same or different manufacturers.
- “OPC UA FX Engineering” represents a design tool used during the commissioning phase to configure physical devices (here, *Controllers A and B*) and 5G network devices in a plant. The roles involved include control engineer, network engineer, security administrator, and system commissioner.
- Configuration data can also be transparently sent via the 5G system for non-5G components, for example for remotely configuring devices. These interactions are beyond the scope of this paper, however. The engineering actions supported by *Controllers A and B* in the 5G system are carried out using data communication provided by the default PDU session, which is established when the user equipment (UE) first registers with the 5G network and allows its operations, administration, and maintenance (OAM) system to remotely control the 5G system for commissioning and provisioning as defined in 3GPP. In the scenario described above, it is assumed that the OAM system can access the network side of the 5G system – for example gNB, UPF, etc. – via a wired network.

**Figure 10:** IP-based OPC UA application deployment options

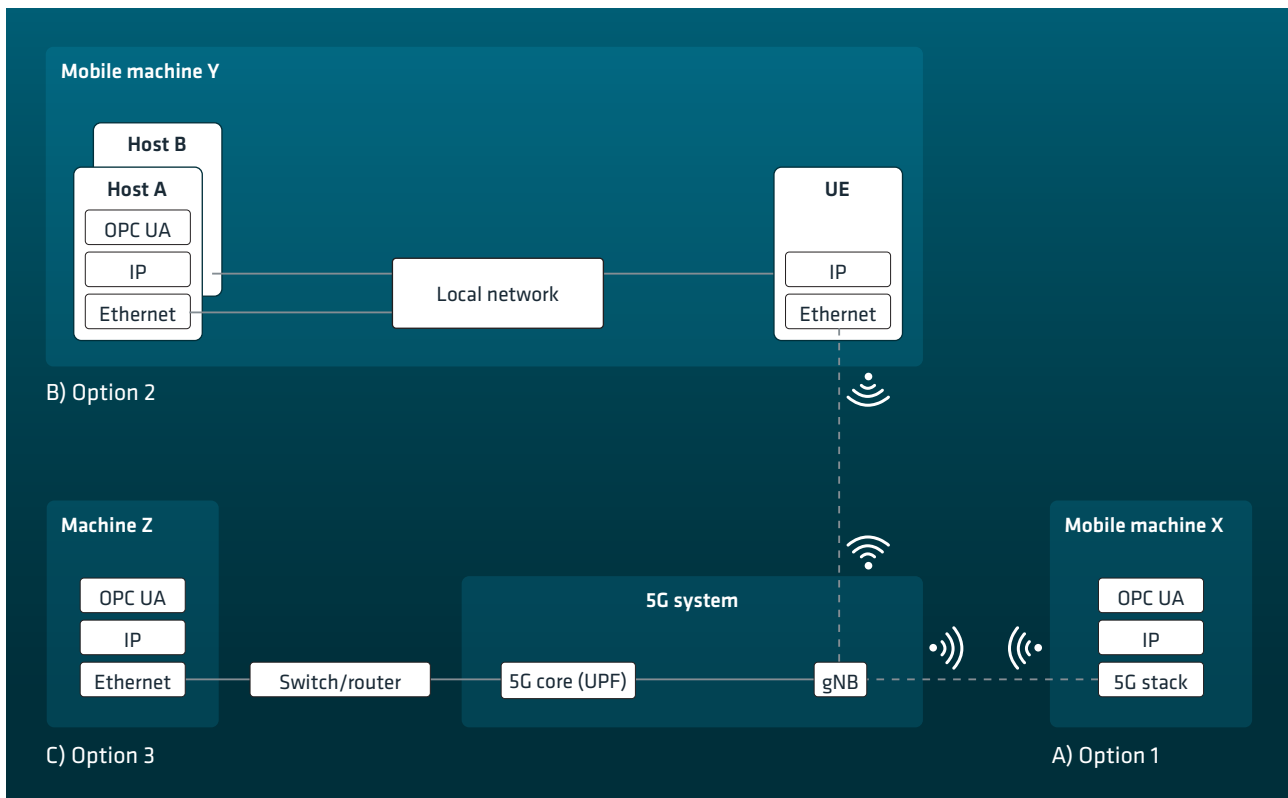

Source: 5G-ACIA / ZVEI e. V.

When 5G is introduced in a factory, hybrid networking may be required to connect wired *Controllers* via 5G networks.

## 4.2 OPC UA Application Deployment Scenarios

It is possible to deploy OPC UA applications in various scenarios, depending on their status in the 5G system:

- (1) Option 1: An OPC UA application is integrated in a UE.
- (2) Option 2: An OPC UA application is in a non-UE device.  
In this case, the UE acts as a 5G router between a wired network and 5G RAN.

- (3) Option 3: An OPC UA application is in an industrial network “behind” the UPF in the data network.

The OPC UA communication model can be either IP-based as shown in figure 10 or Ethernet-based as depicted in figure 11.

**Figure 11:** Ethernet-based OPC UA application deployment options

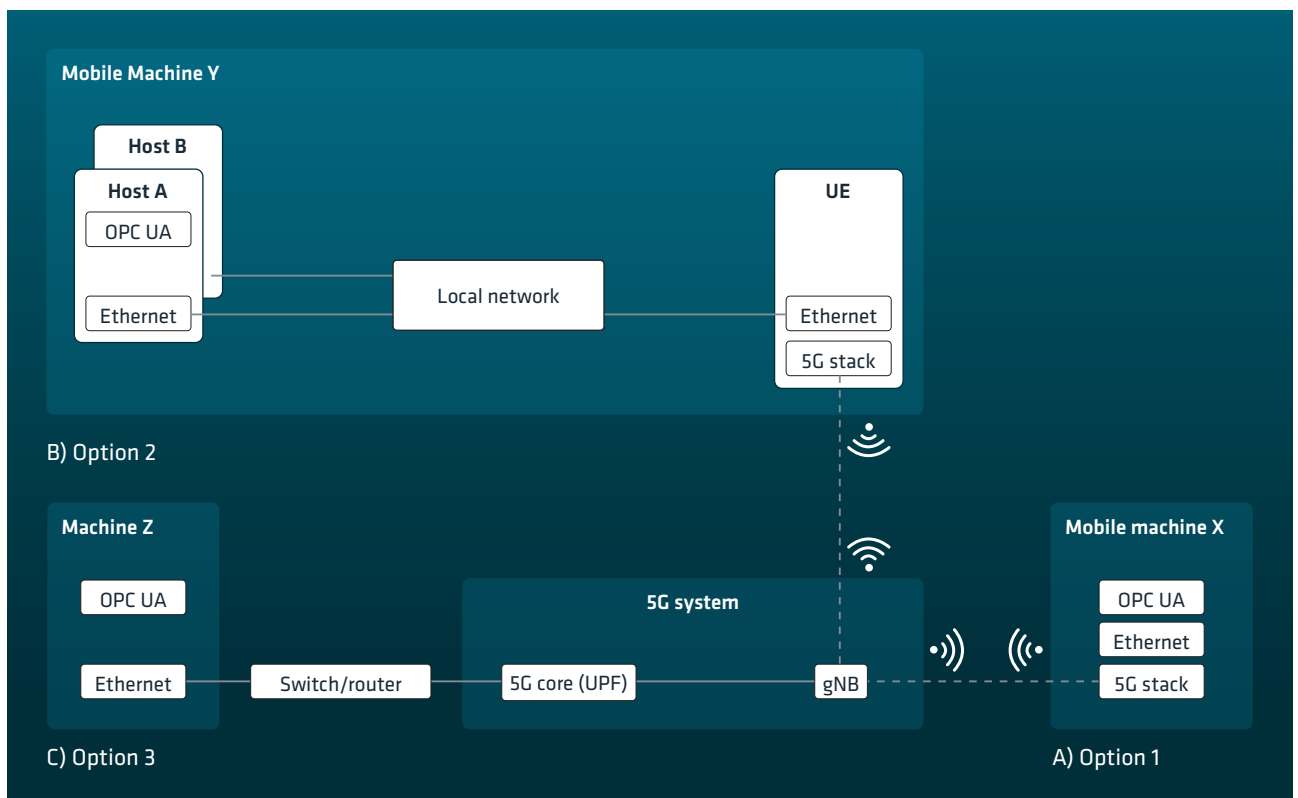

Source: 5G-ACIA / ZVEI e. V.

## 5 5G and OPC UA Integration Architectures

### 5.1 Integration Principles

Either of the following two integration principles can be applied:

**Principle 1:** Low dependency

Here the goal is to preserve the separation of concerns between the 5G system and OPC UA so that each technology can develop independently of the other with minimal functional impacts between them.

**Principle 2:** 5G-native model with more extensive integration

There are two possible approaches for integrating 5G and OPC UA. One is to directly use the 5G system (referred to here as the 5G-native model) and the other is to employ it as a TSN bridge. This document focuses on the 5G-native model, in which the 5G system can meet the requirements of industrial applications without needing to support TSN functionalities.

For a discussion of integrating the 5G system with TSN networks, see the 5G-ACIA white paper “Integration of 5G with Time-Sensitive Networking for Industrial Communications” (reference [4]).

### 5.2 Overall Architecture and Key Interfaces

Figure 12 depicts a high-level system architecture for OPC UA and 5G integration, showing the user, control, and management planes. The black blocks correspond to the OPC UA domain and the white ones to the 5G domain.

The use case and architecture shown in figure 12 illustrate three key aspects of system integration:

1. Transport mapping: *Controllers A* and *B* may need to exchange OPC UA application data in order to perform a shared task via the 5G system. 5G supports two types of PDU sessions for this purpose: Ethernet and IP. The OPC UA application data must be conveyed using one of

them, depending on whether L2 Ethernet connectivity is required across the 5G system.

2. Joint QoS management: The OPC UA application sends the QoS to the 5G system via OPC UA, which maps the application QoS requirements to 5G QoS parameters to establish a traffic transmission link between *Controllers A* and *B*. The 5G system can also send suggested application QoS parameters to the OPC UA application to help it adjust its QoS for better performance and more efficient transmission.
3. Connectivity management: When a 5G device is deployed in a factory network, higher-level IT systems also need to visualize and monitor the 5G network. This in turn makes it necessary to share data from it (such as topology, status, and diagnostic information) with IT systems for condition monitoring, *Asset* management, and/or other scenarios.

#### 5.2.1 Transport Mapping

OPC UA defines two communication models: a Client/Server (CS) model and a PubSub (publish and subscribe) model. The Client/Server communication model is a TCP-based request-response scheme that is mainly used for configuring and establishing logical *Connections* between two functional entities. The PubSub model is designed for transmitting real-time user data.

OPC UA application data can be transported on the 5G user plane via interface A or B; this is a standard 5G user plane capability. The OPC UA Client/Server model only supports TCP/IP transmission, which can be routed via interface A (in the case of IP type PDU sessions) or B (with Ethernet type PDU sessions). For the OPC UA PubSub model, both UDP/IP and Ethernet transport (via interfaces A and B, respectively) are supported. 5G transparently transmits received OPC UA application data.



## 5.2.2 Joint QoS and Connectivity Management

Joint management of QoS and connectivity is needed to properly support transport mapping and ensure good-quality transmission of OPC UA application data over the 5G system. The interface between these two systems therefore plays a crucial role in integrating OPC UA and 5G. As shown in

Figure 12, there are two possibilities (designated as interfaces D and D') for implementing the 5G system's reference points for exposing capabilities.

### Interfaces D and E

Interface D is 3GPP-native, in other words it has been directly defined by 3GPP. It can be implemented in three different ways:

**Figure 12:** High-level system architecture for integrating OPC UA and 5G

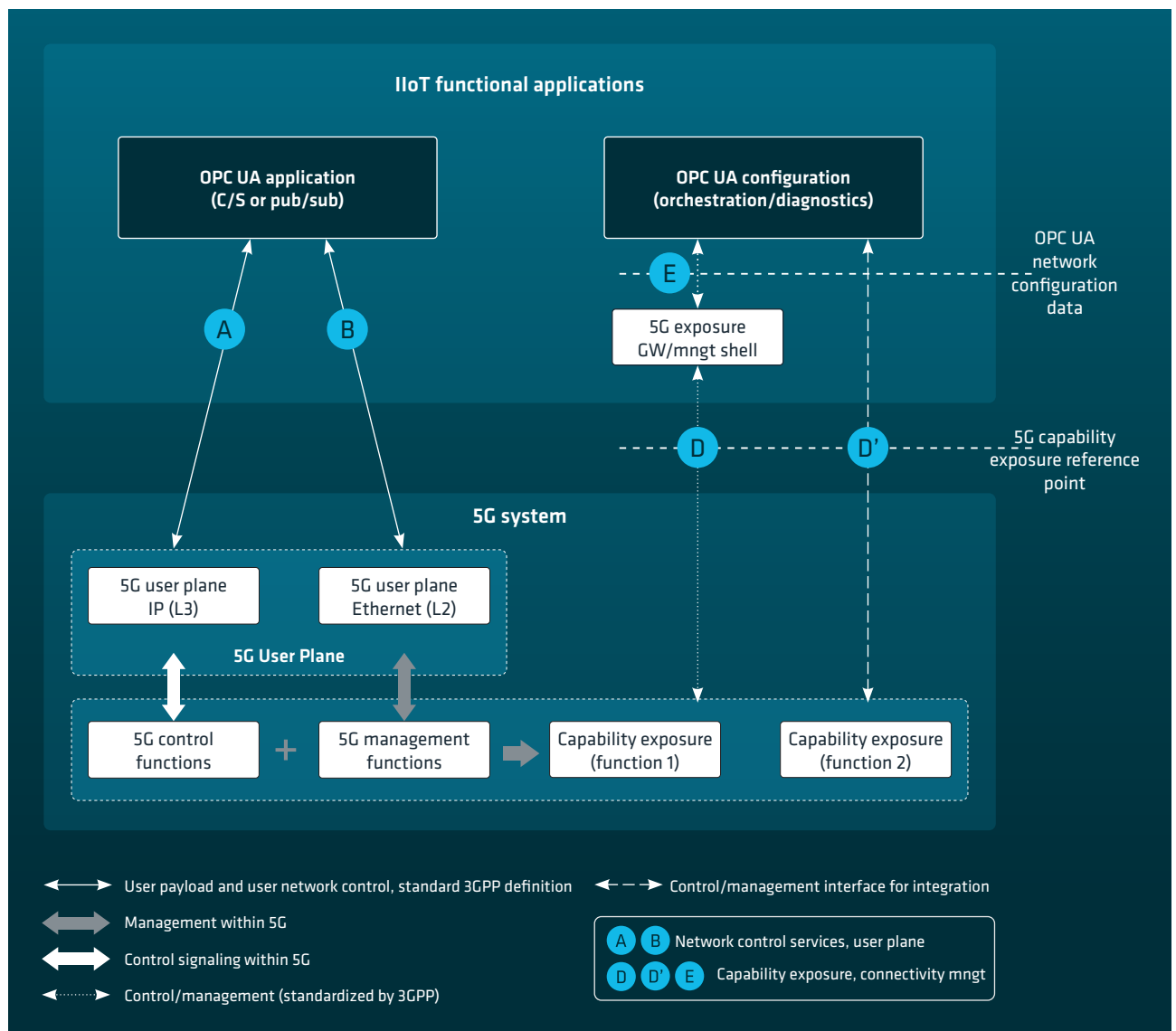

Source: 5G-ACIA / ZVEI e. V.

- 1) Capability exposure using a network exposure function (NEF) defined by 3GPP SA2:  
3GPP SA2 defines a network exposure function (NEF) for exposing 5G system capabilities to external systems via a standardized application protocol interface (API). Specifically, the NEF is connected to an application function (AF), in other words a server in external system via API interfaces. The API is specified in 3GPP TS 29.522; see reference [5].
- 2) Common API Framework (CAPIF) defined by 3GPP SA6:  
3GPP SA6 has introduced a service enabler architecture layer (SEAL) that provides shared or generic services to support vertical applications. Stage 2 for SEAL services is specified in 3GPP TS 23.434 (reference [6]), and the API is specified in 3GPP TS 29.549 (reference [7]).
- 3) Exposure capabilities via network management functions defined by 3GPP SA5:  
3GPP SA5 defines two types of network management services: the RESTful HTTP-based solution set and the YANG/NETCONF-based solution set. For details, see TS 28.532, clause 12.

Interface E is the OPC UA-native interface that OPC UA defines for communicating with lower-layer networks (such as 5G and TSN) for configuration purposes. For OPC UA FX, the interface can be in OPC UA Client/Server mode.

If a 3GPP-native interface D is involved, then use of a 5G exposure gateway/management shell is conceivable. It translates both the protocol and the content of interface D to interface E as shown in Figure 12.

#### **Interface D'**

Interface D' is an OPC UA-native interface with the same functionality as the D and E interfaces mentioned above. If the OPC Foundation and its application developers demand such a native OPC UA interface as described above for 5G, there are two possibilities. The first is to use the set of interfaces provided by 5G system exactly as they are specified by 3GPP (that is, using the protocols and data models defined by 3GPP for controlling such functions from outside the 5G system). If any inadequacy is identified, such as an interface that is un-

able to support successful integration, it must be amended in accordance with the 3GPP technical specifications. 3GPP may develop a new set of interfaces with protocols and data models like those suggested by the OPC Foundation. This would enable the 5G system to use exactly the same protocols and data models as for wired Ethernet *Connections*.

## 6 Joint QoS Management

### 6.1 OPC UA QoS Configuration

OPC UA applications may need a particular QoS for transporting *NetworkMessages*. These QoS requirements must be configurable using only OPC UA resources, without depending in any way on the underlying network technology. This makes it easier to migrate or interconnect OPC UA applications across different network technologies. QoS requirements can also be met with different network mechanisms. Depending on the specified QoS level, different QoS control mechanisms are needed in the network.

OPC UA applications can require best-effort or priority-based QoS for PubSub traffic. The requirements in each case are defined during the application engineering phase independently of the actual QoS configuration in the underlying network, as explained in section 3.4. Control engineers use abstract QoS categories and labels to define an application's QoS requirements. For a given *Connection*, the OPC UA communication stack translates these abstract configurations (categories and labels) into specific priority values in the message using a lookup table called the *PriorityMappingTable*.

*PriorityLabel* is translated into actual values to be used by the network as shown in figures 13 and 14. In addition to an optional *QoSCategory*, the mapping table includes a *PriorityLabel* for the network interface used to transmit the data. This combination is essential for establishing communication. Standard values for *QoSCategory*, together with the corresponding required structures in the *DatagramQoS* array, are *best-effort* and *priority*. This list can be extended by specifications built on top of OPC UA PubSub. Each *QoSCategory* is described in detail by a list of measurable QoS KPIs, such as guaranteed bandwidth or maximum latency in the *DatagramQoS* parameter.

**Figure 13:** Message-oriented middleware for providing QoS

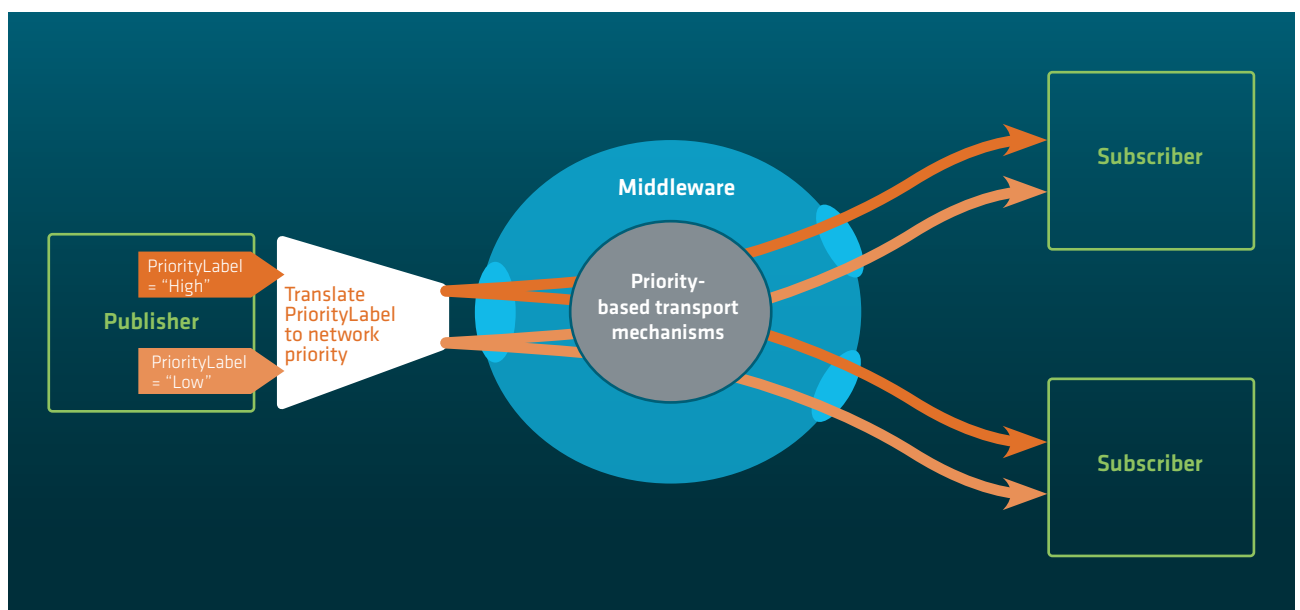

Source: 5G-ACIA / ZVEI e. V.

Figure 14: Mapping of priority-based QoS

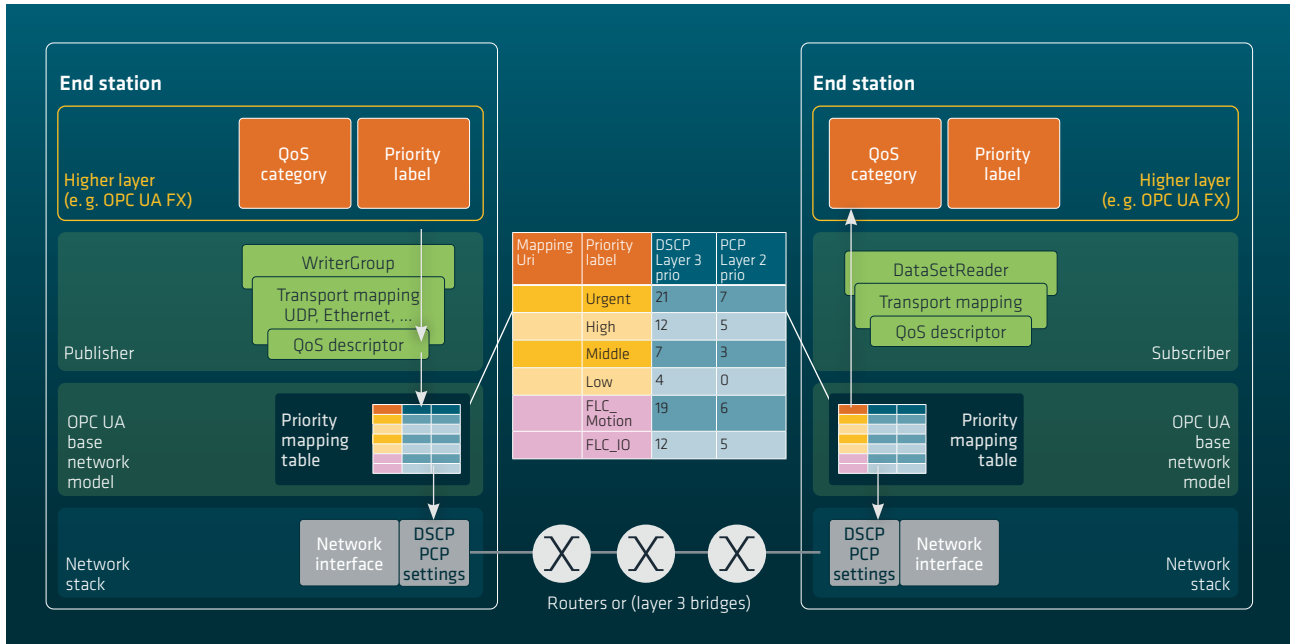

Source: 5G-ACIA / ZVEI e. V.

Figure 15: 5G QoS model

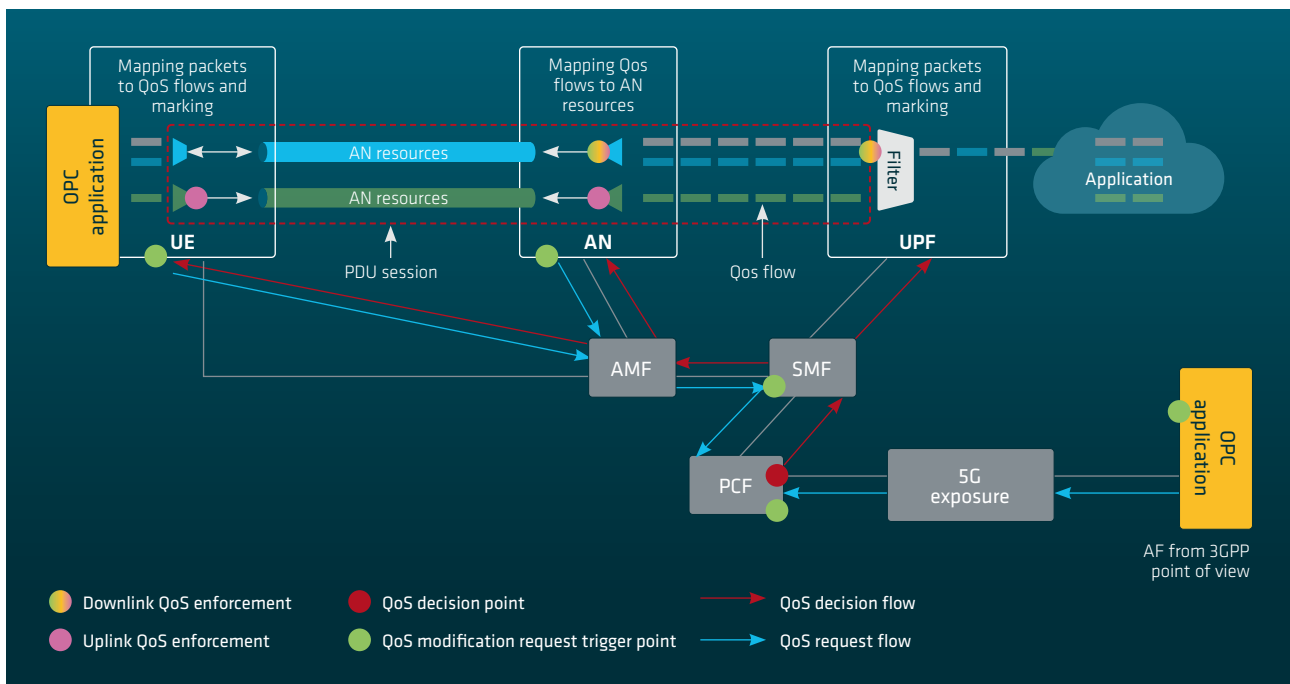

Source: 5G-ACIA / ZVEI e. V.

These QoS requirements have to be met by brokerless, message-oriented middleware. They are therefore mapped to specific network technologies such as TSN, Deterministic Networking (DetNet), 5G, or differentiated services (Diff-Serv). These mappings should be hidden from the application engineer from a PubSub perspective, but may be monitored or configured via the information model.

## 6.2 5G QoS Management

Figure 15 shows the 5G QoS mechanism. The PCF generates the 5G QoS parameters and sends them to UPF/RAN/UE when a PDU session is established or modified. The PCF determines the 5G QoS parameters based on requests received from the OPC UA application (the AF function for 3GPP) and/or the UE. This is done while taking into account the UE's subscription information and the network's configuration and status.

For a more detailed description, see the 5G-ACIA white paper "5G QoS for Industrial Automation" (reference [11]). *Controller-to-Controller* (C2C) communication generally has very strict requirements in terms of end-to-end latency, message integrity, communication service availability, and reliability in alignment with Time-Sensitive Communication (TSC) in 3GPP TS 23.501 (reference [8]).

The AF can provide two types of parameters to the 5G system for QoS management and mapping of AF and 5G QoS parameters, which are shown in figure 16. For more detailed information, see section 6.1.3.22 of 3GPP TS 23.503 (reference [9]).

### Type 1: individual QoS parameters

The AF provides one or more individual QoS parameters: requested priority, maximum burst size, requested delay, requested maximum bitrate, requested guaranteed bitrate, and/or requested packet error rate.

**Figure 16:** Transfer of AF information to the 5G system's QoS parameters

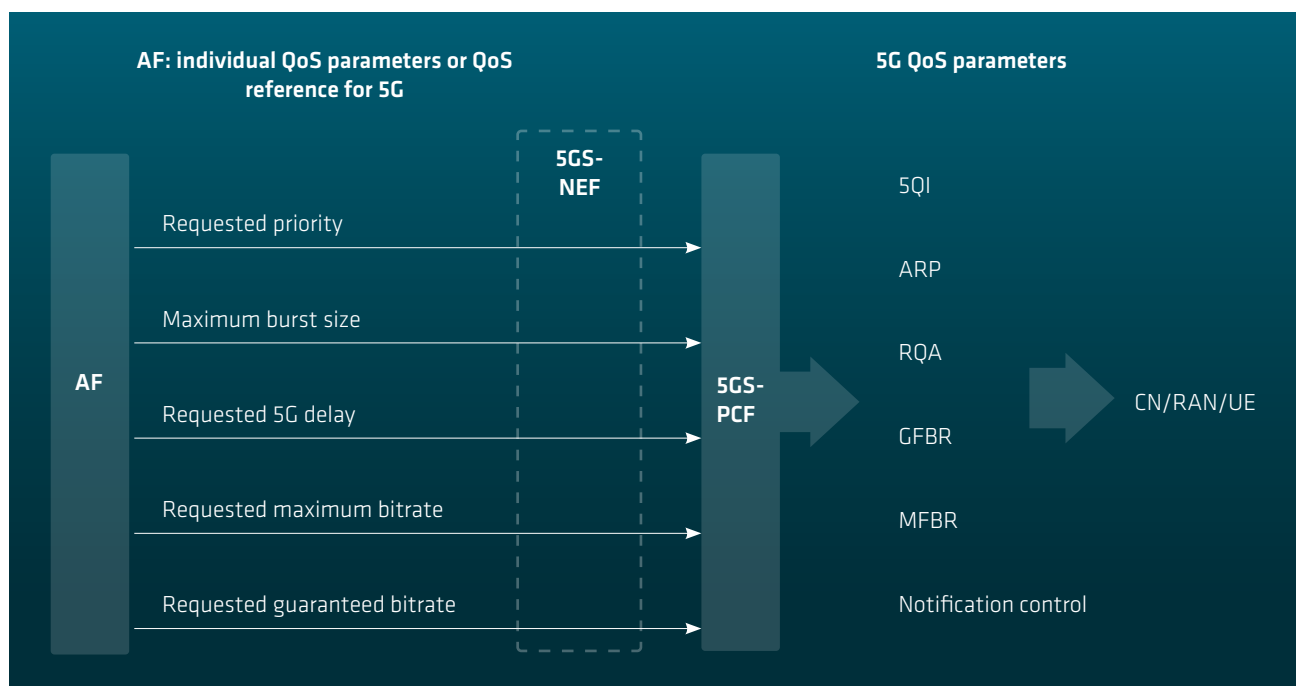

Source: 5G-ACIA / ZVEI e. V.

When the PCF authorizes service information from the AF, it derives the QoS parameters of the PCC rule based on it and specific QoS information received from the AF.

The PCF should select a standardized, preconfigured, or existing dynamically assigned 5QI that matches the individual QoS parameters. If no 5QI matches the QoS parameters, the PCF generates a new, dynamically assigned 5QI derived from them.

A 5QI is a scalar used to reference the following 5G QoS performance characteristics, which define the packet forwarding treatment that a QoS flow receives edge-to-edge between the UE and UPF (see reference [8]):

- Resource type (non-GBR, GBR, delay-critical GBR)
- Priority level
- Packet delay budget (including the core network packet delay budget)
- Packet error rate
- Averaging window (for GBR and delay-critical GBR resource types only)

For TSC services, first the Time Sensitive Communication and Time Synchronization Function (TSCTSF) determines the TSC Assistance Container (defined in table 5.27.2-2 of TS 23.501) based on information provided by an AF/NEF. Then the Session Management Function (SMF) uses the TSC Assistance Container to derive the TSCAI for that QoS flow and route it to the Next Generation Radio Access Network (NG-RAN). The TSCAI is defined in table 1.

**Table 1:** TSC assistance information (TSCAI) (specification 23.501)

Assistance information	Description
Flow direction	Direction of the TSC flow (uplink and downlink)
Periodicity	Time between the starting points of two consecutive data bursts
Burst arrival time (optional)	Latest possible time at which the first packet of the data burst arrives at either the ingress of the RAN (downlink flow direction) or the egress of the UE (uplink flow direction)
Survival time (optional)	As defined in TS 22.261, the amount of time for which an application can survive without any data bursts
Burst arrival time window (BAT window) (optional) (1) (2)	The earliest and latest acceptable arrival times of the first packet of a data burst at either the ingress of the RAN (downlink flow direction) or the egress of the UE (uplink flow direction)
Capability for BAT adaptation (optional) (1)	This indicates that the AF will adjust the burst sending time in accordance with the burst arrival time offset provided by the network (see clause 5.27.2.5).
N6 jitter information (optional) (3)	Jitter information associated with the periodicity in downlink (see clause 5.37.8.1)
Periodicity range (optional) (4)	This indicates that the AF adjusts the periodicity and provides either an acceptable range (upper and lower bounds) or acceptable periodicity value(s) (provided as a list).

(1) Only one of these parameters (BAT window or capability for BAT adaptation) can be provided.

(2) This parameter can only be provided together with the burst arrival time.

(3) Only one of these parameters (burst arrival time or N6 jitter information) may be provided for a given traffic flow.

(4) The periodicity range can only be provided together with periodicity if both the burst arrival time and burst arrival time window are known.

Source: 5G-ACIA / ZVEI e. V.

The TSCTSF provides the TSC Assistance Container to the PCF and forwards it to the SMF, which derives the required QoS parameters of the PCC rule from that information.

#### Type2: QoS reference

The AF provides a QoS reference to predefined QoS information for determining QoS parameters. When the PCF authorizes service information from the AF, it applies the PCC rule to derive QoS parameters from the service information and indicated QoS reference (indicated by its 5QI value). Standardized or preconfigured 5G QoS characteristics are indicated by 5QI values and not signaled on any interfaces unless certain 5G QoS characteristics are modified to enable it.

## 6.3 Joint QoS Management Between OPC UA and 5G

### 6.3.1 5G QoS Derived from *PriorityLabel*

In alignment with the workflow described in section 3.4, Figure 17 shows the joint QoS management mechanism for OPC UA and 5G. During the application engineering phase, engineer B uses available offline or online engineering tools to configure the QoS and addresses for each *Connection* between controllers A and B by setting *Address*, *QosCategory*, and *PriorityLabel*. Engineer B uses a vendor-specific engineering tool to deploy the *Connection* configuration including QoS requirements in *Controller B*. Then the *ConnectionManager*

Figure 17: QoS management for OPC UA FX and 5G integration

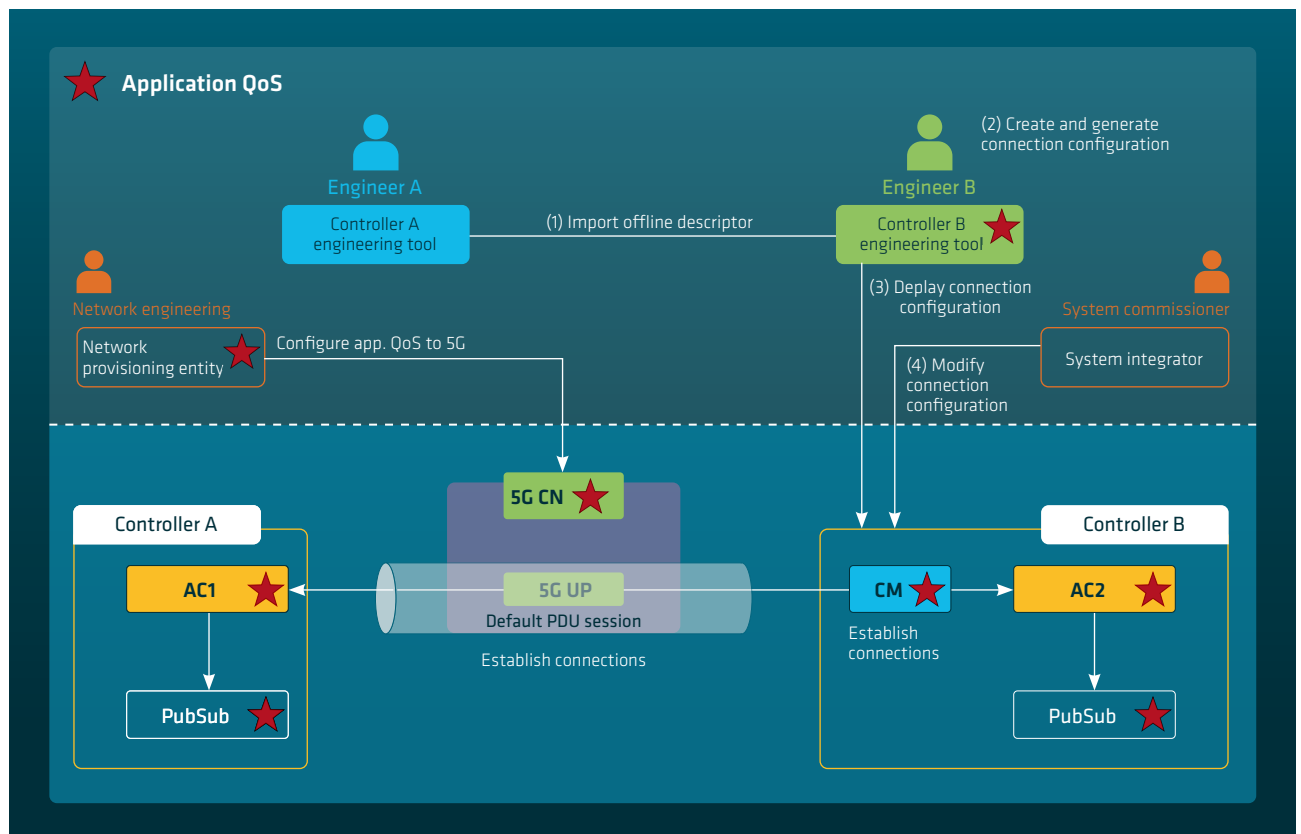

Source: 5G-ACIA / ZVEI e. V.

(CM) configures the QoS requirements for both controllers by calling the *EstablishConnections* method, see reference [10].

In the network commissioning phase, the Network Provisioning Entity configures QoS requirements for the 5G system, which in turn expects to generate 5G QoS parameters from either individual QoS parameters or a QoS reference for establishing connectivity. QoS mapping should be carried out to enable smooth system integration.

As mentioned in section 6.1, the QoS requirements defined in OPC UA FX specification may only include transport priority, while the 5G system needs QoS parameters such as packet error rate and packet delay budget. Scenario 1 is proposed for implementing such a QoS mapping scheme. In section 6.3.2 below, this is taken further with the evolution of OPC UA FX. As an alternative to mapping QoS from *PriorityLabel*, OPC UA and 5G are allowed to negotiate certain parameters such as the application's burst arrival time (BAT) and survival time.

**Scenario 1:** *PriorityLabel* mapped to a scalar value representing a set of 5G QoS parameters

In this scenario, *PriorityLabel* is mapped to PCP and/or DSCP applying the priority mapping table, and PCP and DSCP are translated into 5G QoS values using the 3GPP-specific QoS mechanism, which applies traffic filters to identify the traffic and associate it with 5G QoS classes.

For example, the 5G traffic filter can be set to identify Ethernet traffic marked with a particular PCP value, for example PCP = 3, and associate it with a 5G QoS class with a 5QI value; for example, 5QI = 8 corresponds to Internet-like traffic without a guaranteed bit rate (see TS 23.501, clause 5.7.4) or another value such as PCP = 4 for a 5G QoS class with a different 5QI value, for example 5QI = 83 for discrete automation. The traffic filter and the associated 5G QoS classes are provided to the end device, that is to the 3GPP UE, by the 5G core network based on the 5G commission and configuration. See reference [11] for additional details on this mechanism for associating traffic with 5G QoS.

For this case, OPC UA and the 5G system need to define the mapping table so that it will be consistently translated to PCP or DSCP across both systems and meet the same traffic transmission requirements.

**Figure 18:** Mapping between *PriorityLabel* and 5G QoS

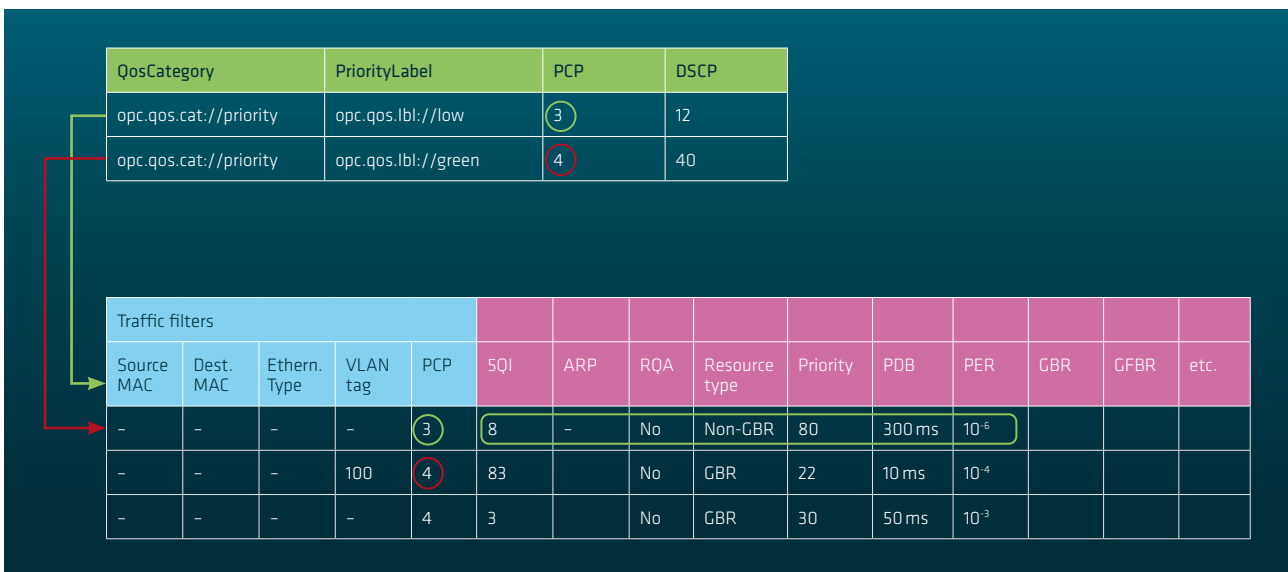

Source: 5G-ACIA / ZVEI e. V.



It should be noted that the 5G traffic filters make it possible to distinguish traffic based not only on PCP and DSCP, but also on the other parameters contained in the protocol header, such as VLAN, destination IP address and so on (see TS 23.501, clause 5.7.6).

### 6.3.2 5G QoS Derived from Extended QoSDataType

In addition to *PriorityLabel*, the OPC Foundation is currently discussing the possibility of extending *QoSDataType* to include additional elements such as bandwidth, *TransmitQosOffset*, *ReceiveQosOffset*, latency, etc. (see reference [12]) as shown in figure 19.

To enable time-sensitive communication, the 5G system requires additional QoS parameters from an application external to the 5G system (see table 1). These measurable QoS KPIs describe the specific traffic characteristic and help 5G ensure the required transmission performance. Scenario 2 is proposed for implementing TSC service when 5G acts as a low-layer network.

With extended *QoSDataType* information, 5G can make full use of radio resources and adopt a more appropriate scheduling strategy for improving transmission efficiency. Extending the following *QoSDataTypes* for lower-layer networks has been proposed.

**Scenario 2:** OPC UA transfers the extended QoS data type to 5G for deriving QoS parameters

**Figure 19:** Use of QoS data types for QoS characterization (source: p. 68 of reference [12])

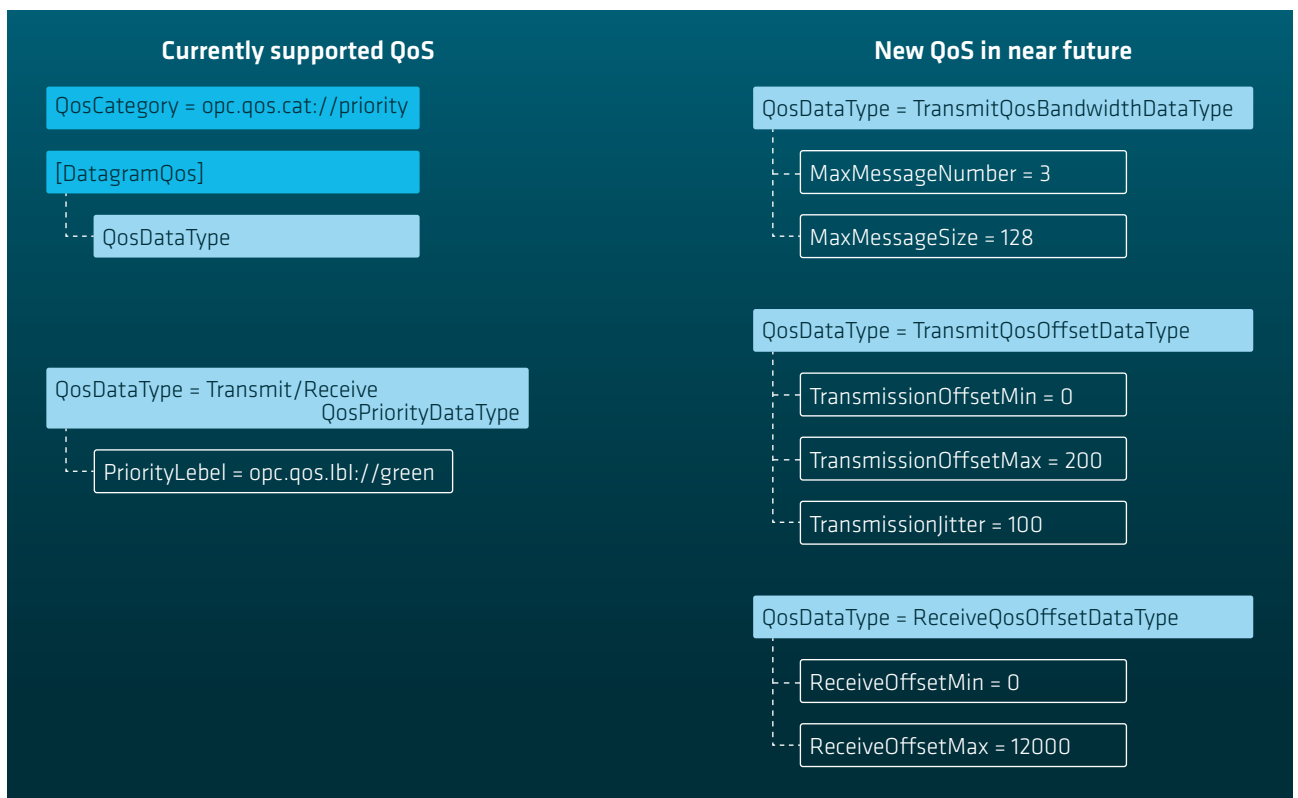

Source: 5G-ACIA / ZVEI e. V.

*Burst arrival time (BAT) and periodicity*

With cyclic traffic, semi-persistent scheduling (SPS) is used to transmit data on the RAN side. However, if the selected transfer interval is quite short (for example 2 ms, corresponding to a sampling rate of 500 Hz), it is difficult for the 5G system to meet stringent latency requirements if a data packet misses the first transmission slot (which typically lasts only 250 microseconds) as shown in figure 20. This can result in a greater transmission latency than is allowed. One way to resolve this problem is for 5G to appropriately adjust the transmission schedules to minimize the delay caused by waiting.

As stated above, the UAFX also takes *TransmitQosOffset* and *ReceiveQosOffset* as candidates for the extended *QosDataType*. Further evaluation is needed to determine whether these parameters could map with BAT and periodicity.

An alternative solution for enabling the 5G system to adapt its transmission schedules to cyclic data bursts is to ask the application to shift its cyclic traffic. This would be particularly useful when the network load is unevenly distributed, since the applications themselves would typically determine

when to start their transmission cycles. There can be a large number of arrivals during certain time intervals while traffic in others is especially low, resulting in inefficient use of network resources. In such a case, it can help to ask a subset of applications to adjust their data bursts, in other words their transmission cycles, to distribute traffic more evenly.

To achieve this, the 5G system can suggest a BAT for senders and the OPC UA application can then adjust the transmission time (by modifying *TransmitQosOffset*) in response to feedback received from 5G. If the OPC UA application doesn't adopt the suggested BAT, it could suggest alternative adjustment values to the 5G system, one of which is then selected for reducing their interactions.

In a dual-ended wireless scenario, the OPC UA application needs to inform 5G of the relationship between the two QoS flows/traffic so the RAN can choose an appropriate offset. In other words, admission of the two QoS flows should be coordinated.

**Figure 20:** Illustration of a mismatch between the arrival time of a packet and its actual transmission

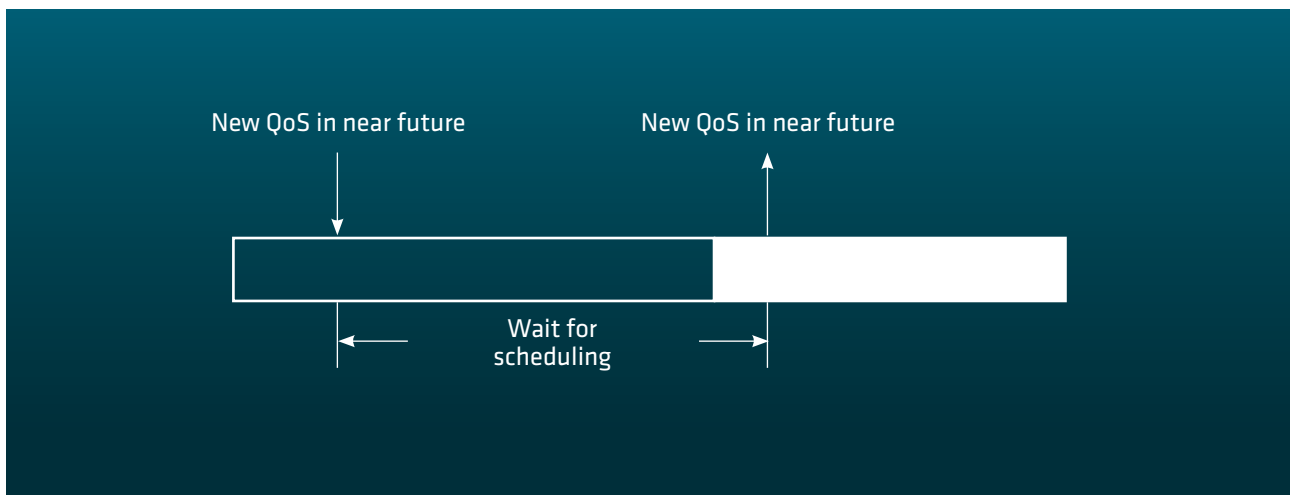

Source: 5G-ACIA / ZVEI e. V.

### *Survival time*

Survival time is the time during which an application using a communication service can continue doing so after failing to receive an expected message (TS 22.261, clause 3.1). This helps ensure continuity of service. The 5G system also takes the survival time into account for determining how reliably the communication service operates.

For example, suppose that the set survival time results in two consecutive packets being missed. When the loss of the first packet is detected – making transmission of the next packet crucial for the application’s continued operation – 5G may at that point choose to increase the reliability level for the second packet in order to ensure continuity of service. It is therefore suggested that the OPC Foundation include survival time as a new subtype of *QoSDataType* for use in the 5G network.

### *Indication of redundant information*

The capacity of air interfaces always poses challenges, especially when supporting TSC-related services with high QoS requirements. The following measures could help 5G address bottlenecks in industrial scenarios.

1) **Padding compression:** The application-layer packet payload of industrial applications is usually small (approx. 20 bytes), but many padding bits are added for the sole purpose of filling it out to the required minimum size of 64 bytes for an Ethernet frame as defined in IEEE 802.3. This is clearly redundant and results in inefficient utilization of network resources, especially in air interfaces. To overcome this, the OPC UA application could indicate whether or not empty (and therefore unnecessary) padding bits are present and if so where the padding starts and ends, in order to help reduce 5G’s transmission load. As shown in figure 20, the size of an Ethernet frame to be transmitted in the 5G system can be reduced to 22 bytes of padding, in addition to compressing the Ethernet header as is already done in 5G.

2) **Reduce redundant messages:** Application-layer packets typically transmit exactly the same information over and over again, for example on temperature. The data only changes when there is an alarm. There is no need to transmit these unchanging packets across an air interface. Enabling an OPC UA application to provide packet detection information to 5G could help reduce unnecessary bits and increase capacity.

## 6.4 Interface for Joint QoS Management

As shown in 5.2.2, two kinds of interfaces support the exposure of capabilities between OPC UA and 5G and can also be used for joint QoS management:

- Interfaces D and E:
  - Interface D is defined by 3GPP and can be implemented by NEF and CAPIF.
  - Interface E is defined and configured by OPC UA using Client/Server mechanisms.
- Interface D’
  - Interface D’ has the same functionality as interfaces D and E. Since OPC uses a Client/Server mechanism for configuring the transport layer, interface D’ can be regarded as equivalent to a Client/Server model.

# 7 Connectivity Management

## 7.1 OPC UA FX Controller Connectivity Management Service Integration Analysis

OPC UA FX uses *ConnectionManager* (CM) to establish Pub-Sub *Connections*. Communication between controllers (and devices) and CM is based on a Client/Server model.

Figure 21 shows two different options for deploying a CM: in a UAFX device at the field level and at a central location as a separate entity. In the first option (top left), the UAFX device holds an *AutomationComponent* (AC) containing a *FunctionalEntity* (FE) that may be willing to publish or subscribe to real-time data. The other option is to deploy the CM as a standalone entity, for example at the multi-access edge or behind a data network. Following the connection configuration procedure, if a UAFX device A hosting the AC\_1 wants

to establish *Connections* among multiple functional entities over a communication network, for example to another UAFX device B hosting the AC\_2, it sends a request to the CM to initiate establishment of a logical *Connection* between the two FEs. The CM then interacts with the *Network Provisioning Entity* (NPE) to verify that the required network resources are available. If it receives a positive response, the CM then calls the *EstablishConnections* method for each individual AC to make sure that every endpoint is correctly configured with the right *ConnectionConfigurationSet*.

Figure 21: Example manager deployments (reference [1], p. 12)

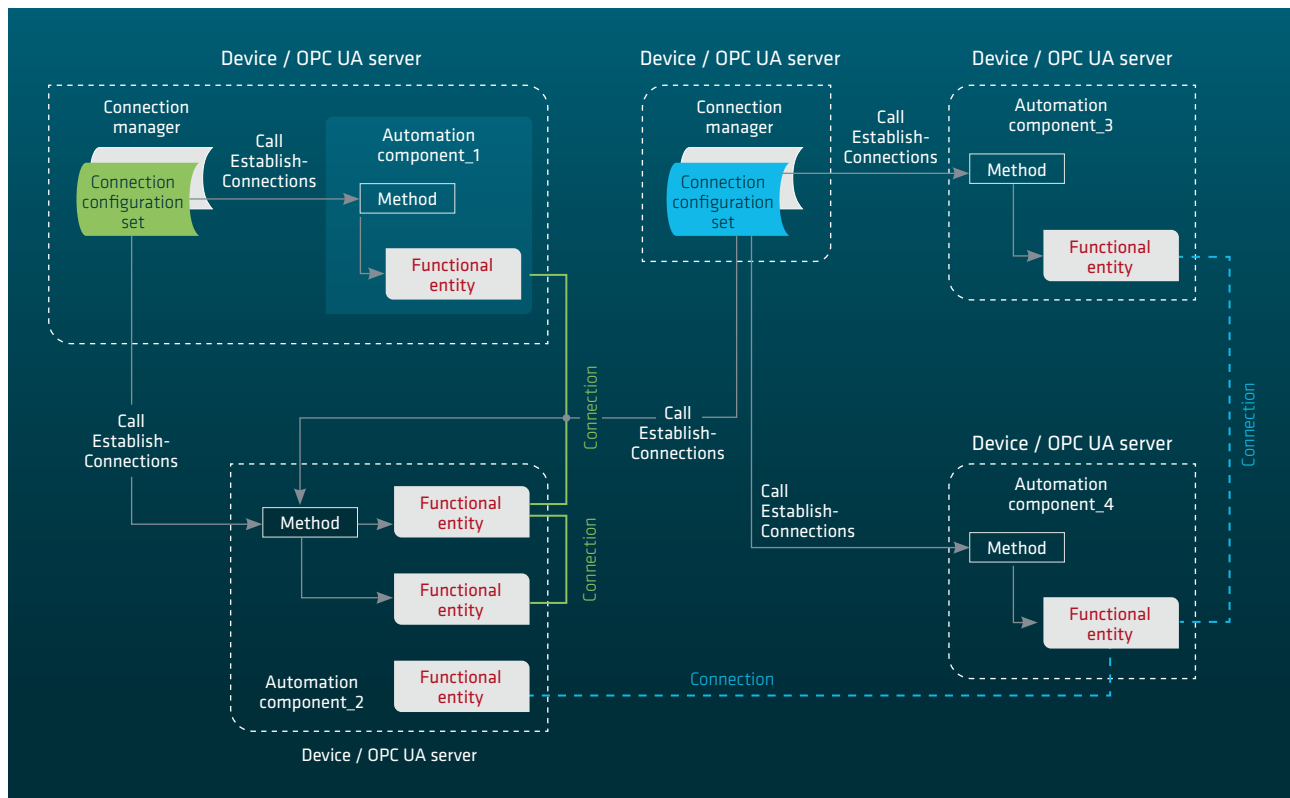

Source: 5G-ACIA / ZVEI e. V.

Figure 22 shows a possible sequence involving two ACs and a CM during the *EstablishConnections* procedure.

As already mentioned, this procedure follows a Client/Server communication model while the PubSub model is used to exchange real-time data. This is shown again in figure 23: FEs use PubSub communication separately from the Client/Server communication used to establish *Connections*. Note that executing the connection establishment procedure relies on exchange messages, implying that user plane connectivity already exists between the two UAFX devices A and B. This can be accomplished with the default PDU session that is established when the UE is powered up.

When a PDU session is established, the 5G network applies default QoS rules to create one or more QoS flows. This is illustrated in figure 24 by QoS Flow#1, which carries Ethernet frames. The default QoS rules can be configured in the 5G system by OAM or AF using the 5G exposure function. QoS Flow#1 can be used to send configuration data during the commissioning phase.

**Figure 22:** Sequence for establishing connections, with two automation components

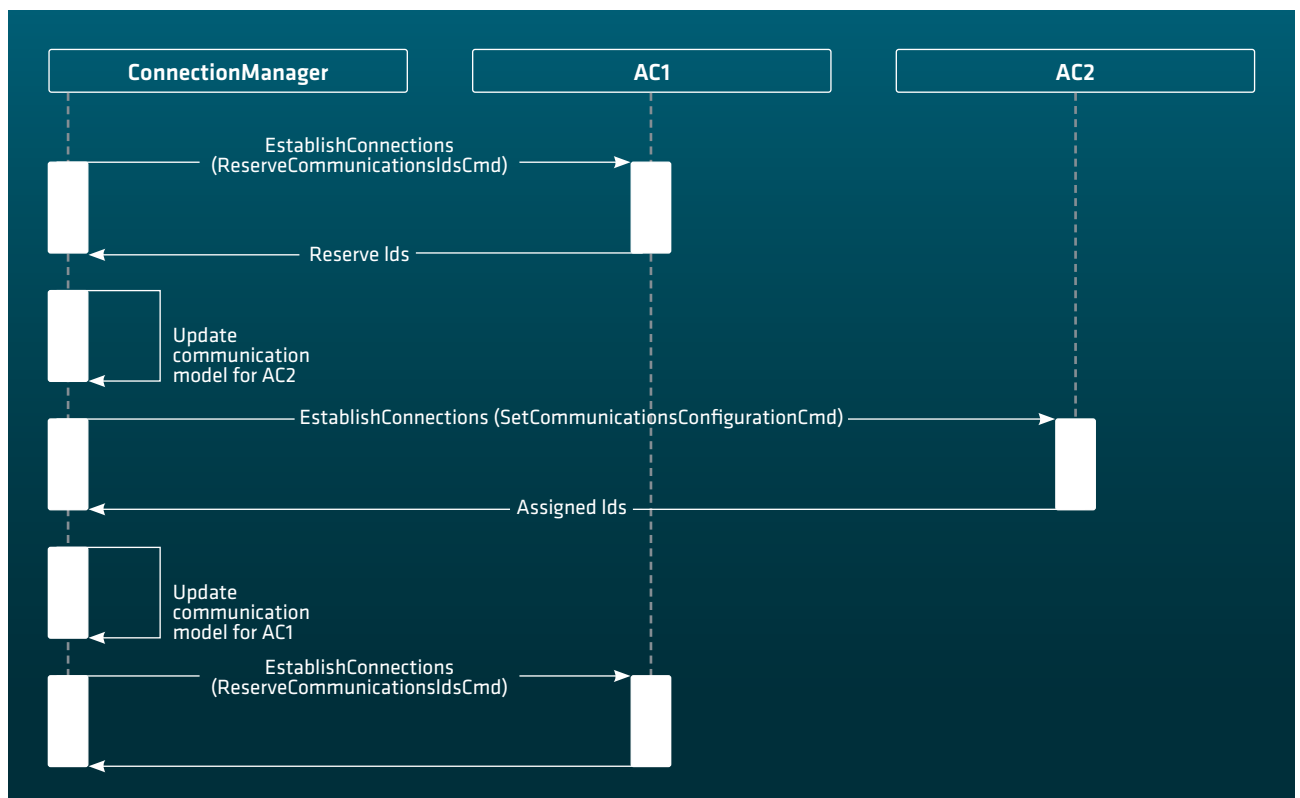

Source: 5G-ACIA / ZVEI e. V.

When the application requests to transmit data packets with a QoS different from that of QoS Flow#1 – for example, by opening a new socket in or sending data to the transport layer (depending on how the operating system is implemented, this may be beyond the scope of 3GPP) – the detecting UE requests to initiate establishment of an IP-type PDU session with the requested QoS. As shown in figure 24, the UE can send the requested 5G QoS to 5G’s control functions. If the 5G core network receives a request from the UE to establish a PDU session, it checks whether the requested QoS is compatible with the current network status, available resources, and configurations in order to determine whether the requested

QoS can be provided. If so, network resources are appropriately allocated and a QoS flow for transmitting traffic data is set up. Reference [11] provides additional details and examples of this.

Note that the UE is unable to indicate the BAT, periodicity, or other traffic characteristics or parameters shown in table 1.

Alternatively, the OPC UA configuration server can use the Nnef\_AFSession service with the 5G core network’s AF (as an example) to request modification of the PDU session. The OPC UA configuration server incorporates either the individ-

**Figure 23:** Establishment of Client/Server connections and PubSub communication as separate QoS flows

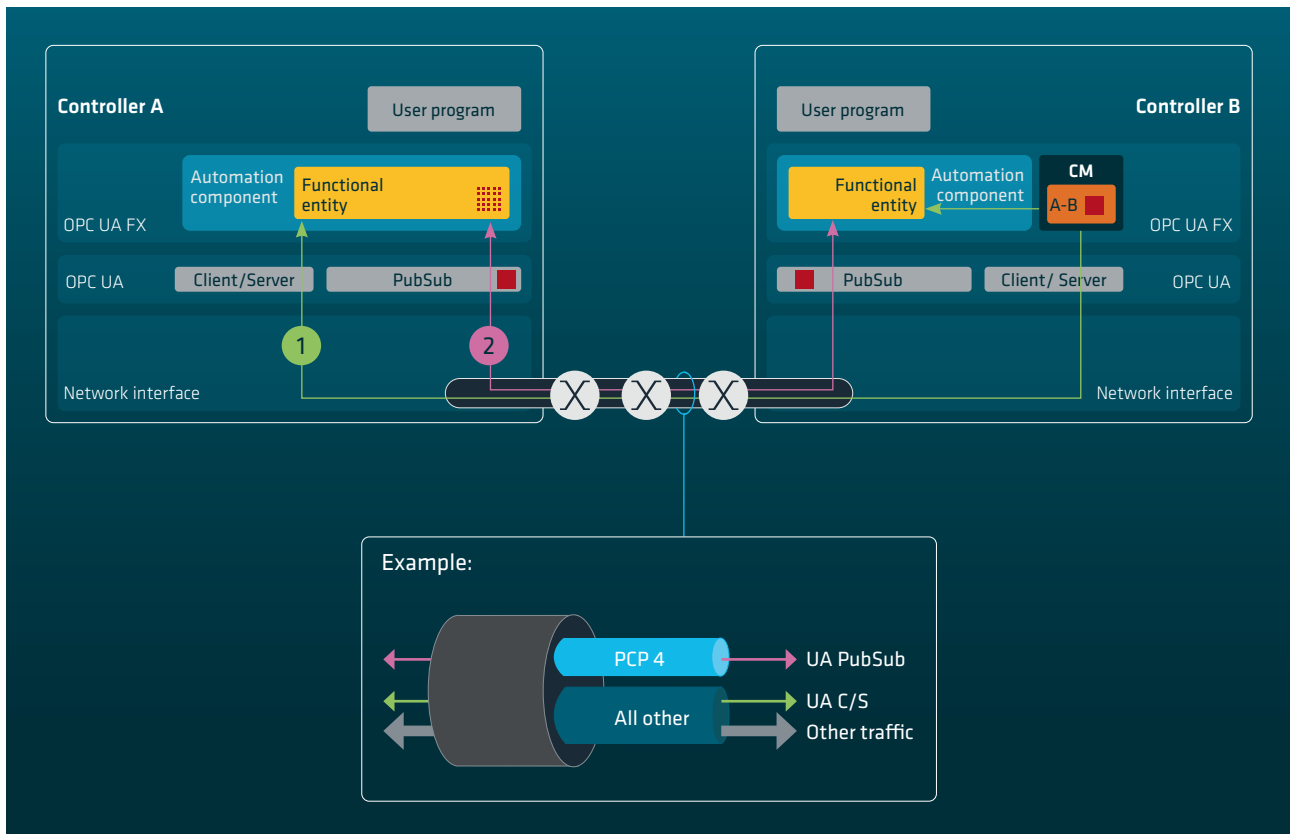

Source: 5G-ACIA / ZVEI e. V.

ual QoS parameters or the QoS reference into the Nnef\_AF-Session\_Create service operation.

## 7.2 Exposure of 5G Connectivity Management Services

It is important to note that in mobile networks, as opposed to wired networks, after a configuration has been performed the UE is the entity that initiates establishment of connectivity. In other words, the core network is unable to establish PDU sessions if it has user plane data to transmit. The UE is therefore also unable to receive any data packets routed to it unless a default PDU session has already been established at power-up.

The OPC UA FX application connectivity requirements should be represented or mapped to the QoS requirements in 5G. OPC UA FX Connections are configured using *ConnectionConfigurationSet*. Configuration information per *ConnectionEndPoint* contains the addresses of the automation component and functional entity, verification and application configuration parameters, variables to be transmitted and/or received, and communication parameters such as publishing interval, timeouts, and QoS. The configuration information also indicates modifiable parts and their predefined ranges.

**Figure 24:** A UE requests PDU session establishment to set up required QoS flow

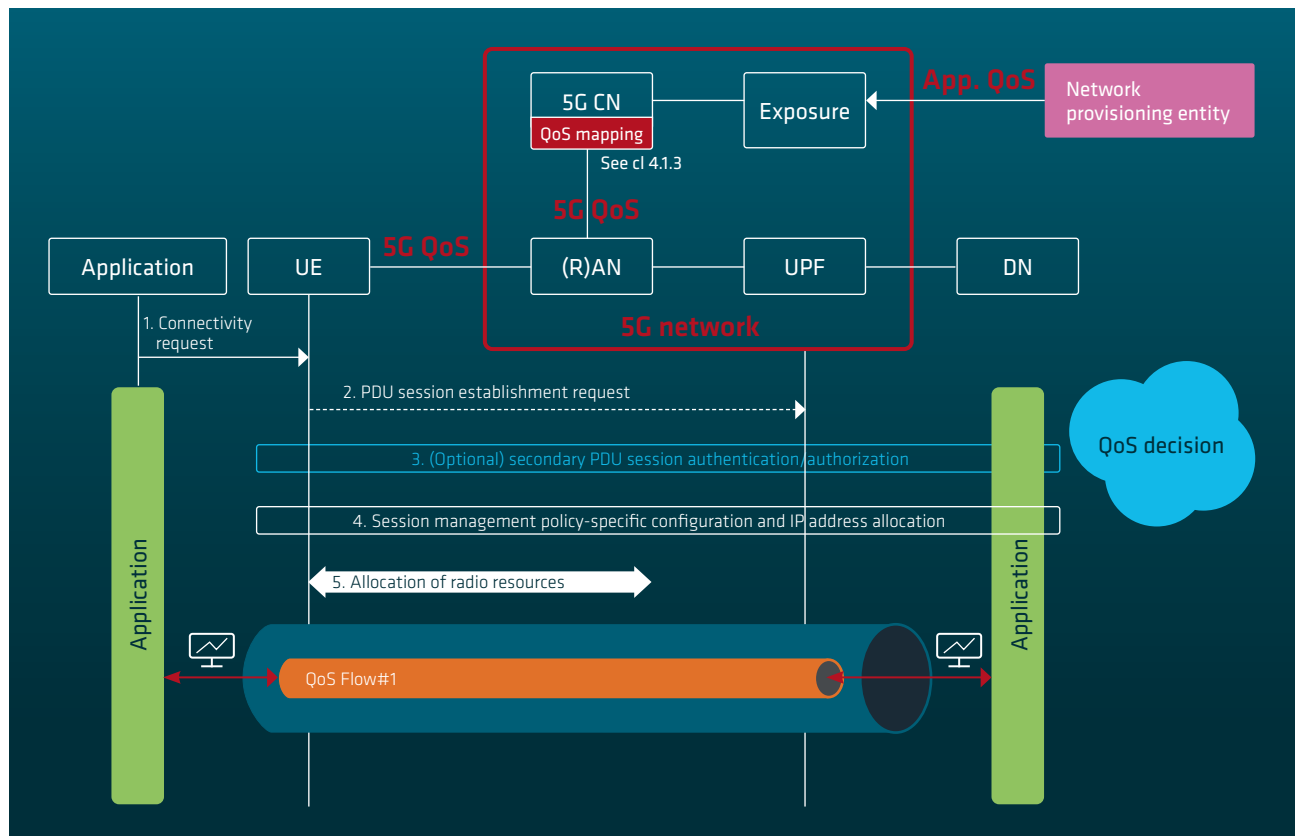

Source: 5G-ACIA / ZVEI e. V.

To ensure sufficient capabilities for managing connectivity, the possibility of enabling interfaces between the OPC UA system and 5G (at the network management level) to exchange information on the following aspects could be considered:

- Network planning and configuring capabilities: Based on the QoS requirements of a single *Connection* (as well as application scenario-related attributes such as *coverageArea*, *uEMobilityLevel* and *termDensity* in *ServiceProfile* in 3GPP TS 28.541, clause 6.3.3 (see reference [13])), the 5G network management system can schedule network resources to support industry use cases. It is proposed that the OPC UA provide information required for network planning, including a *ConnectionConfigurationSet* value for each *Connection* and the number of connections. 5G could expose capabilities for network configuration (for example, by adding, modifying, or removing network slices/members within a network slice (on the SIM level)), modifying the QoS, or restarting part of 5G (including RAN, UPF, and control-plane NEs).
- QoS monitoring capability for end-to-end *Connections*: QoS monitoring is essential for providing guaranteed KPIs (essential 5G-ACIA requirements). 5G can provide QoS and network monitoring capabilities to OPC UA via interface D' or D + E. The monitoring capabilities that could potentially be provided for OPC UA are:
  - Monitoring of an E2E network connection (resources, status, and KPIs)
  - Monitoring of a network slice (topology, resources, status, and KPIs)
  - Monitoring of UE (resources, status, and KPIs)
  - Monitoring of the topology, resources, status, and KPIs of a network (including RAN, UPF, and control-plane NFs)

This information enables the industry to see how 5G provides *Connections* for industrial devices and monitors their status.

- QoS verification and optimization capabilities: Clause 6.23 of TS 22.261 defines QoS monitoring requirements, specifying that these can be used for assessing and ensuring the dependability of commu-

nication services in 5G systems. Clause F.1 of the same specification discusses how QoS monitoring information can be used for assurance. Under “customer rating of QoS,” it mentions that the customer can check the QoS achieved by the provider against the QoS requirements and their own experience.

5G can therefore provide capabilities for testing a connection's QoS to the OPC UA, including a service simulation and dialing test and checking of terminal connectivity and network performance.

As discussed in section 4.15 of 3GPP TS 23.435, the solution includes an application layer procedure. This involves verifying the QoS by interacting with the 5G core and OAM to collect QoS-related data, network and service quality of experience (QoE) data from the terminal side, and application QoE data from the VAL server and then checking whether it all matches actual customer QoE data.

## 7.3 Interface for Connectivity Management Services

As discussed in 5.2.2, two kinds of interfaces support capability exposure between OPC UA and 5G. Both of them can also be used for managing connectivity:

- Interfaces D and E:
  - Interface D is defined by 3GPP's RESTful HTTP-based and YANG/NETCONF-based solution sets. For details, see TS 28.532, clause 12.
  - Interface E is defined by OPC UA using Client/Server mechanisms for configuration.
- Interface D'
  - Interface D' has the same functionality as interfaces D and E. Since both OPC UA and OPC UA FX use a Client/Server mechanism to enable configurations for the transport layer, interface D' can be regarded as equivalent to the Client/Server model.



## 8 Conclusions

OPC UA is a platform-independent standard that is used for communication among various types of devices and systems in the industrial domain. In order to integrate OPC UA FX with the 5G system, it is important to understand the core principles of the OPC UA, since the 5G system is the medium for establishing and maintaining connectivity between the components and various automation functions represented by *FunctionalEntities* (FEs).

This report provides an overview of OPC UA FX and then investigates how it could be integrated with 5G and assesses its technology readiness level. The following aspects are addressed:

- Designing the overall integration architecture for integrating OPC UA FX with 5G, which includes transport mapping, joint QoS management, and connectivity management.
- Exploring the joint QoS management scheme between OPC UA and 5G, for which two mapping options are explored:

- Mapping *PriorityLabel* to a scalar value representing a set of 5G QoS parameters
- Transfer by OPC UA of the extended *QosDataType* to 5G for deriving 5G QoS parameters

- Exploring possibilities for exchanging connectivity management information when 5G is integrated in an industrial network, focusing on the aspects of network planning and configuration capabilities, QoS monitoring capability for end-to-end connections, and QoS verification and optimization capabilities.

The analysis reveals a need to integrate the ICT and OT domains, which in turn calls for interfaces between the OPC UA and 5G systems and exchangeable parameters as prerequisites for providing good-quality communication services. 5G-ACIA and the OPC Foundation have shared their thoughts on the possibility of collaborating to complete this ongoing project and agreed that it is only the first step toward integration and further study is required. It is important to develop the OPC UA FX and 3GPP specifications further as a prerequisite for more detailed work.

## 9 Abbreviations and Acronyms

<b>3GPP</b>	3 <sup>rd</sup> Generation Partnership Project	<b>TSCTSF</b>	Time Sensitive Communication and Time Synchronization Function
<b>5G-ACIA</b>	5G Alliance for Connected Industries and Automation	<b>UAFX</b>	OPC UA Field eXchange
<b>5QI</b>	5G QoS identifier	<b>UE</b>	User equipment
<b>AF</b>	Application function	<b>UPF</b>	User plane function
<b>API</b>	Application programming interface		
<b>FE</b>	Functional entity		
<b>CAPIF</b>	Common API Framework		
<b>IIoT</b>	Industrial Internet of Things		
<b>OPC</b>	Open Platform Communications		
<b>OPC UA FX</b>	OPC UA Field eXchange		
<b>OAM</b>	Operation and maintenance		
<b>PCC</b>	Policy and charging control		
<b>RAN</b>	Radio access network		
<b>SPS</b>	Semi-persistent scheduling		

OPC UA is a registered trademark of the OPC Foundation. OPC UA FX and UAFX are trademarks of the OPC Foundation.

## 10 References

- [1] OPC UA Technical Specification Part 81, “UAFX Connecting Devices and Information Model” v1.00.00, November 2022.
- [2] OPC Foundation white paper “Extending OPC UA to the field: OPC UA for Field eXchange (FX)” v2, November 2021 (URL: <https://opcfoundation.org/wp-content/uploads/2020/11/OPCF-FLC-Technical-Paper-C2C.pdf>).
- [3] 3GPP Technical Specification 22.104, “Service requirements for cyber-physical control applications in vertical domains,” v19.1.0, September 2023, [https://www.3gpp.org/ftp/Specs/archive/22\\_series/22.104/](https://www.3gpp.org/ftp/Specs/archive/22_series/22.104/).
- [4] 5G-ACIA white paper “Integration of 5G with Time-Sensitive Networking for Industrial Communications.”
- [5] 3GPP Technical Specification 29.522, “Network Exposure Function Northbound APIs; Stage 3,” v18.2.0, June 2023.
- [6] 3GPP Technical Specification 23.434, “Service Enabler Architecture Layer for Verticals (SEAL); Functional architecture and information flows,” v18.5.0, June 2023.
- [7] 3GPP Technical Specification 29.549, “Service Enabler Architecture Layer for Verticals (SEAL); Application Programming Interface (API) specification; Stage 3” v18.2.0, June 2023.
- [8] 3GPP Technical Specification 23.501, “System Architecture for the 5G System (5GS); Stage 2,” v18.2.2, July 2023.
- [9] 3GPP Technical Specification 23.503, “Policy and charging control framework, Stage 2,” v18.2.0, June 2023.
- [10] OPC UA Technical Specification, Part 82, “UAFX Networking,” v1.00.00.
- [11] 5G-ACIA white paper, “5G QoS for industrial Automation”.
- [12] Joint Workshop 5G-ACIA / OPC Foundation (February 21, 2023).
- [13] 3GPP Technical Specification 28.541, “5G Network Resource Model (NRM); Stage 2 and Stage 3,” v18.4.1, June 2023.

## **5G-ACIA White Paper**

Integration of OPC UA in 5G Networks

### **Contact**

5G-ACIA  
Lyoner Strasse 9  
60528 Frankfurt am Main  
Germany  
Phone: +49 69 6302-209  
Email: [info@5g-acia.org](mailto:info@5g-acia.org)  
[www.5g-acia.org](http://www.5g-acia.org)

### **Published by**

ZVEI – German Electro and Digital Industry Association,  
5G-ACIA - 5G Alliance for Connected Industries and  
Automation, a Working Party of ZVEI  
[www.zvei.org](http://www.zvei.org)

Published in March 2024

### **© ZVEI e. V.**

This work, including all of its parts, is protected by copyright. Any use outside the strict limits of copyright law without the consent of the publisher is prohibited. This applies in particular to reproduction, translation, microfilming, storage, and processing in electronic systems. Although ZVEI has taken the greatest possible care in preparing this document, it accepts no liability for the content.

Design: COBRAND

# 11 5G-ACIA Members

As of February 2024





[5G-ACIA.org](https://5G-ACIA.org)